

US
05|2016

GERWAH®

Metal Bellows & Servo-Insert Couplings, Line Shafts



Partner for Performance
www.ringfeder.com

 **RINGFEDER**
POWER TRANSMISSION



Welcome to your system supplier for every aspect of power transmission



RINGFEDER POWER TRANSMISSION

- We say what we mean and mean what we say.
- We see things from our customers' perspective.
- We are considerate of our employees and their families as well as our environment and the society.

RINGFEDER POWER TRANSMISSION is the global market leader in the niche markets of drive technology and is well regarded for its customer-specific, application-oriented solutions that ensure excellent and failure-free operation for its clients.





Mars Rover:
Courtesy NASA/
JPL-Caltech

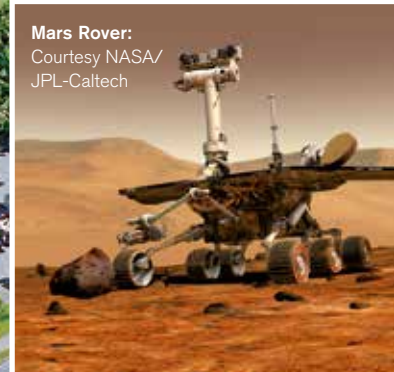

We offer locking devices, couplings, bearing housings and damping technology for OEMs but also for the final customer under our strong brand names RINGFEDER, TSCHAN, HENFEL and GERWAH. Our brand ECOLOC supplies reliable products off the shelf.

We not only provide competent advice to our customers on the basis of our 90 years of experience but also develop innovative ideas in cooperation with them. This is part of our aspiration to be a **Partner for Performance**.

Around the power transmission we promise

- Excellent know-how for our challenging customers
- Best cost-benefit ratio
- Short reaction times and a high product availability





Metal Bellows Couplings

Servo-Insert Couplings

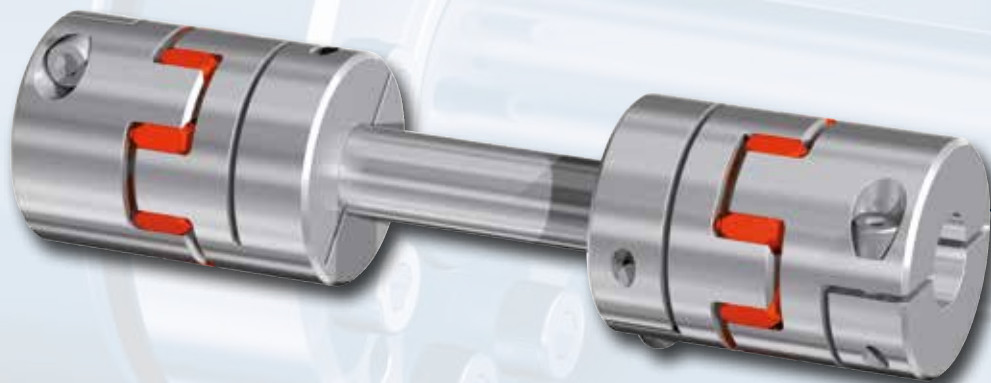

Line Shafts

Content

02 **Pages Corporate Image**

04 **Overview**

05 **Content**

Metal Bellows Couplings

06 **Basics**

08 **Product Overview**

10 GERWAH® **EKN**

12 GERWAH® **DKN**

14 GERWAH® **DKN/S**

16 GERWAH® **PKA**

18 GERWAH® **PKB**

20 GERWAH® **PKN**

22 GERWAH® **AKN**

24 GERWAH® **AKN-H**

26 GERWAH® **AKD**

28 GERWAH® **AKD-H**

30 GERWAH® **AK**

32 GERWAH® **CKN**

34 **Technical Information**

Servo-Insert Couplings

36 **Basics**

39 **Product Overview**

40 GERWAH® **GWE 5102**

42 GERWAH® **GWE 5103**

44 GERWAH® **GWE 5103.1**

46 GERWAH® **GWE 5107**

48 GERWAH® **GWE 5104**

50 GERWAH® **GWE 5106**

52 GERWAH® **GWE 5112**

54 **Technical Information**

56 **ISO Tolerances**

Line Shafts

57 **Basics**

59 **Product Overview**

60 GERWAH® **GWZ 5104.1**

62 GERWAH® **GWZ 5106.1**

64 GERWAH® **GWZ 5116**

66 GERWAH® **GWZ 5106**

Mounting Instructions

68 **Metal Bellows Couplings**

70 **Servo-Insert Couplings**

71 **Line Shafts**

72 **Critical bending speed**

Fax Inquiry

74 **Fax Inquiry Couplings**

75 **Fax Inquiry Line Shafts**

76 **Online Service**

78 **Product Range**

RINGFEDER POWER TRANSMISSION

CAD data available:
www.ringfeder.com

All technical details and information are non-binding and cannot be used as a basis for legal claims. The user is obligated to determine whether the represented products meet his requirements. We reserve the right at all times to carry out modifications in the interests of technical progress. Upon the issue of this catalogue all previous brochures and questionnaires on the products displayed are no longer valid.

Metal Bellows Couplings Basics

Backlash-free Metal Bellows Couplings

Characteristics of Metal Bellows Couplings:

- Backlash-free transmission of torque
- High torsional stiffness, precise transmission of rotational angle
- Different torsional stiffness
- Compact design, low moment of inertia
- Metal bellows made of stainless steel
- Simple and safe assembly
- Compensation of radial, axial and angular misalignment
- Free of wear, maintenance-free, no downtimes
- Not sensitive to temperatures between -22 °F and +212 °F
- Nominal torques between 0.4 ft-lbs – 3688 ft-lbs



GERWAH®

**Premium
Metal Bellows Couplings
with 20% higher torques!**

Advantages

- 100% inspection and traceability through individual marking
- Higher torques at same dimensions
- Compact design
- Extended bore ranges
- Customer-specific solutions
- Higher safety in application, e.g. no wrong screw tightening torques

Metal Bellows Couplings Basics

Backlash-free Metal Bellows Couplings are used in the sector of mechanical engineering, where torque or rotary motion has to be transmitted from shaft to shaft with the highest accuracy of angle.

- Pumps with axial and vertical drives
- High dynamic portal drives
- Spindle lifting units
- Linear units
- Packaging machines
- Machine tools
- Special machines



Overview Metal Bellows Couplings



GERWAH®
EKN

Miniature metal bellows coupling with radial set screws

Page 10



GERWAH®
DKN

Miniature metal bellows coupling with clamping hubs

Page 12



GERWAH®
DKN/S

Miniature metal bellows coupling with clamping hubs and expanding clamps

Page 14



GERWAH®
PKA

Metal bellows coupling with axial pluggable clamping hub

Page 16



GERWAH®
PKB

Metal bellows coupling with axial pluggable locking ring

Page 18



GERWAH®
PKN

Metal bellows coupling with pluggable clamping hub

Page 20

Overview Metal Bellows Couplings



GERWAH®
AKN

Metal bellows coupling with clamping hubs, short length and higher torsional stiffness

Page 22



GERWAH®
AKN-H

Metal bellows coupling with clamping hubs, short length and higher torsional stiffness in split hub design

Page 24



GERWAH®
AKD

Metal bellows coupling with clamping hubs

Page 26



GERWAH®
AKD-H

Metal bellows coupling with clamping hubs in split hub design

Page 28



GERWAH®
AK

Metal bellows coupling with inner conical hub

Page 30



GERWAH®
CKN

Metal bellows coupling with flange

Page 32

CAD data available:
www.ringfeder.com

Dimensions

- $d_1; d_{2min}$ = Min. bore diameter
 $d_1; d_{2max}$ = Max. bore diameter
 $d_{1k}; d_{2kmin}$ = Min. bore diameter with keyway acc. to DIN 6885-1
 $d_{1k}; d_{2kmax}$ = Max. bore diameter with keyway acc. to DIN 6885-1
 C_1 = Guided length in hub boring d_1
 D_1 = Outer diameter hub
 l = Distance between center screw hole and hub end
 L = Total length



Dimensions

Size	$d_1; d_2$ min-max Without keyway	$d_{1k}; d_{2k}$ min-max With keyway	C_1	D_1	l	L
	inch					
4	0.118 - 0.354	0.236 - 0.315	0.236	0.630	0.079	0.787/0.906/1.024
9	0.118 - 0.354	0.236 - 0.315	0.236	0.630	0.079	0.827/0.984/1.102
15	0.118 - 0.472	0.236 - 0.394	0.394	0.787	0.118	0.984/1.181
20	0.118 - 0.630	0.236 - 0.551	0.433	0.984	0.079	1.024/1.260/1.417
45	0.236 - 0.866	0.236 - 0.630	0.630	1.299	0.157	1.535/1.890
100	0.236 - 1.102	0.236 - 0.984	0.787	1.575	0.157	1.732/2.126

Transmission of the couplings transmissible torque T can no longer be guaranteed for certain with borings $< d_{min}$. Types with borings $< d_{min}$, however, can be supplied. Moment of inertia and weight (mass) are calculated with reference to the largest bore size.

Characteristics

- Metal bellows made of stainless steel, hubs made of aluminum
- The shaft tolerance should be within the fit tolerance "g6" or "h7"
- The contact surfaces have to be free from oil and grease

The torque values shown in the technical data tables can only be safely transmitted if all instructions are followed.

Ordering example: EKN

Series Size	Length L	Bore diameter d_1	Bore diameter d_2	Further details*
EKN 20	1.024	0.236	0.393	*

* Keyway

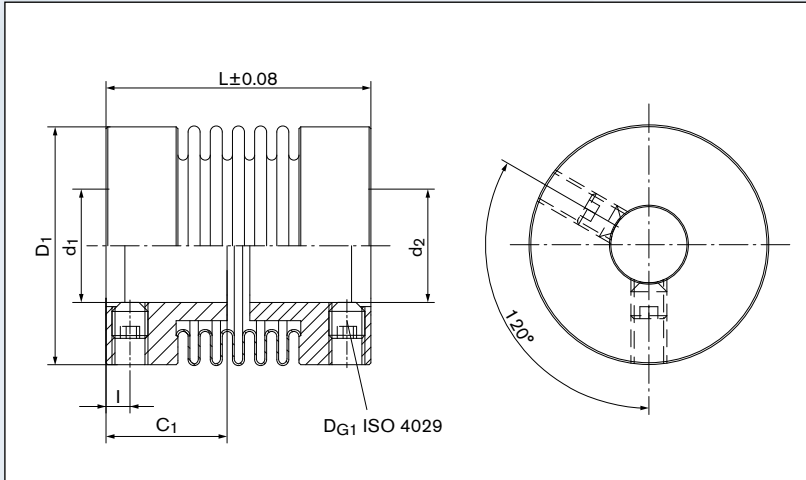

Sectional view EKN

Technical Data

- T** = Transmissible torque at given T_A
- n_{max}** = Max. rotation speed
- C_{Tdyn}** = Dynamic torsional stiffness
- C_r** = Radial spring stiffness
- C_a** = Axial spring stiffness
- ΔK_a** = Max. permissible axial misalignment
- ΔK_w** = Max. permissible angular misalignment
- ΔK_r** = Max. permissible radial misalignment
- J** = Total moment of inertia
- Gw** = Weight
- D_{G1}** = Thread
- T_{A1}** = Tightened torque of clamping screw D_{G1}

Technical Data

Size	T	n_{max}	C_{Tdyn}	C_r	C_a	ΔK_a	ΔK_w	ΔK_r	J	Gw	D_{G1}	T_{A1}
	ft-lbs	rpm	10^3 ft-lbs/rad	lbs/inch	lbs/inch	inch	Degree	inch	lbs-in ²	lbs	mm	ft-lbs
4	0.4	15000	0.18/0.14/0.11	731/308/148	103/74/63	0.008/0.012/0.016	1.2/2.0/2.0	0.004/0.006/0.008	0.0007	0.01/0.01/0.02	1 x M3	0.37
9	0.8	15000	0.37/0.28/0.22	1068/468/240	206/154/126	0.008/0.012/0.016	1.2/2.0/2.0	0.004/0.006/0.008	0.0007/0.0008/0.0009	0.01/0.02/0.02	1 x M3	0.37
15	1.3	15000	0.55/0.52	794/463	69/131	0.010/0.016	1.2/2.0	0.004/0.006	0.0026/0.0027	0.03	2 x M4	1.11
20	1.8	15000	1.11/0.96/0.74	839/548/263	103/80/51	0.012/0.016/0.020	1.2/2.0/2.0	0.004/0.008/0.010	0.0048/0.0055/0.0058	0.04	2 x M3	1.11
45	4.1	15000	4.79/2.95	2535/617	268/166	0.012/0.020	1.2/2.0	0.004/0.008	0.0232/0.0249	0.11	2 x M6	2.21
100	8.9	15000	5.97/4.94	2061/1102	263/194	0.016/0.020	1.2/2.0	0.006/0.010	0.0683/0.0752	0.11/0.13	2 x M6	2.21

Transmissible torque T [Nm]

Size	\varnothing mm																				
	3	4	5	6	7	8	9	10	11	12	13	14	15	16	17	18	20	22	24	26	28
	\varnothing inch																				
4	0.118	0.157	0.197	0.236	0.276	0.315	0.354	0.394	0.433	0.472	0.512	0.551	0.591	0.630	0.670	0.707	0.787	0.866	0.945	1.023	1.102
4	0.4	0.4	0.4	0.4	0.4	0.4	0.4	---	---	---	---	---	---	---	---	---	---	---	---	---	---
9	0.7	0.5	0.8	0.8	0.8	0.8	0.8	---	---	---	---	---	---	---	---	---	---	---	---	---	---
15	1.3	1.3	1.3	1.3	1.3	1.3	1.3	1.3	1.3	1.3	---	---	---	---	---	---	---	---	---	---	---
20	1.8	1.8	1.8	1.8	1.8	1.8	1.8	1.8	1.8	1.8	1.8	1.8	1.8	1.8	1.8	1.8	1.8	1.8	1.8	---	---
45	---	---	---	4.1	4.1	4.1	4.1	4.1	4.1	4.1	4.1	4.1	4.1	4.1	4.1	4.1	4.1	4.1	4.1	---	---
100	---	---	---	5.4	6.3	7.2	8.1	8.9	8.9	8.9	8.9	8.9	8.9	8.9	8.9	8.9	8.9	8.9	8.9	8.9	8.9

Dimensions

$d_1; d_{2min}$	= Min. bore diameter
$d_1; d_{2max}$	= Min. bore diameter
$d_{1k}; d_{2kmin}$	= Min. bore diameter with keyway acc. to DIN 6885-1
$d_{1k}; d_{2kmax}$	= Max. bore diameter with keyway acc. to DIN 6885-1
C_1	= Guided length in hub boring
D_1	= Outer diameter hub
H	= Clearance diameter
I	= Distance between center screw hole and hub end
K	= Distance shaft axis - clamping screw axis
L	= Total length



Dimensions

Size	$d_1; d_2$ min-max		C_1	D_1	H	I	K	L
	Without keyway	With keyway						
	inch	inch	inch	inch	inch	inch		inch
4	0.118 - 0.315	0.236 - 0.315	0.276	0.630	0.709	0.094	0.197	0.827/0.945/1.102
9	0.118 - 0.315	0.236 - 0.315	0.276	0.630	0.709	0.094	0.197	0.906/1.024/1.181
15	0.118 - 0.394	0.236 - 0.394	0.354	0.787	0.827	0.118	0.276	1.024/1.181
20	0.118 - 0.551	0.236 - 0.551	0.433	0.984	1.063	0.138	0.354	1.260/1.496/1.654
45	0.197 - 0.669	0.236 - 0.669	0.512	1.299	1.339	0.177	0.472	1.614/1.969
100	0.197 - 0.945	0.236 - 0.945	0.551	1.575	1.654	0.189	0.630	1.850/2.244

Transmission of the couplings transmissible torque T can not longer be guaranteed for certain with borings $< d_{min}$. Types with borings $< d_{min}$, however, can be supplied. Moment of inertia and weight (mass) are calculated with reference to the largest bore size.

Characteristics

- Metal bellows made of stainless steel, hubs made of aluminum
- The shaft tolerance should be within the fit tolerance "g6" or "h7"
- The contact surfaces have to be free from oil and grease
- Optional special design in stainless steel

The torque values shown in the technical data tables can only be safely transmitted if all instructions are followed.

Ordering example: DKN

Series Size	Length L	Bore diameter d_1	Bore diameter d_2	Further details*
DKN 20	1.654	0.236	0.394	*

* Keyway or stainless steel

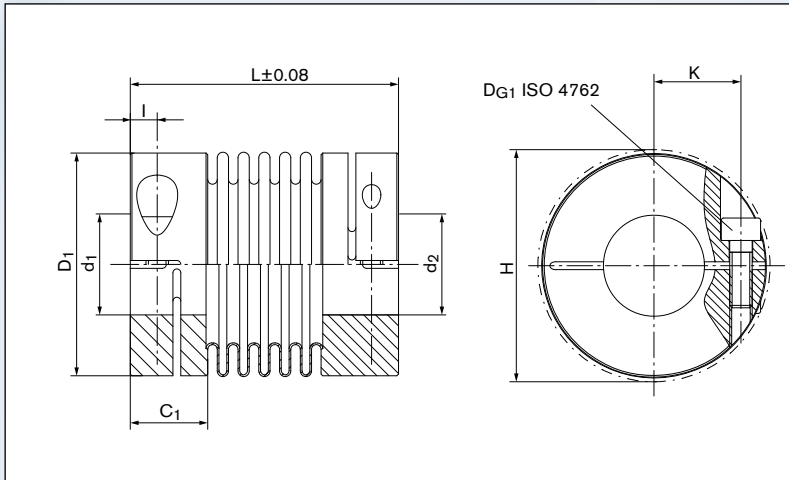

Sectional view DKN

Technical Data

- T** = Transmissible torque at given T_A
- n_{max}** = Max. rotation speed
- C_{Tdyn}** = Dynamic torsional stiffness
- C_r** = Radial spring stiffness
- C_a** = Axial spring stiffness
- ΔK_a** = Max. permissible axial misalignment
- ΔK_w** = Max. permissible angular misalignment
- ΔK_r** = Max. permissible radial misalignment
- J** = Total moment of inertia
- Gw** = Weight
- DG1** = Thread
- T_{A1}** = Tightened torque of clamping screw DG1

Technical Data

Size	T	n_{max}	C_{Tdyn}	C_r	C_a	ΔK_a	ΔK_w	ΔK_r	J	Gw	DG1	T_{A1}
	ft-lbs	rpm	10^3 ft-lbs/rad	lbs/inch	lbs/inch	inch	Degree	inch	lbs-in ²	lbs	mm	ft-lbs
4	0.4	15000	0.18/0.14/0.11	731/308/148	103/74/63	0.008/0.012/0.016	1.2/2.0/2.0	0.004/0.006/0.008	0.0009	0.01/0.01/0.02	1 x M2	0.2
9	0.8	15000	0.37/0.28/0.22	1068/468/240	206/154/126	0.008/0.012/0.016	1.2/2.0/2.0	0.004/0.006/0.008	0.0009/0.0010/0.0011	0.01/0.02/0.02	1 x M2	0.2
15	1.3	15000	0.55/0.52	794/463	131/69	0.010/0.016	1.2/2.0	0.004/0.006	0.0038/0.0041	0.03	1 x M2.5	0.6
20	1.8	15000	1.11/0.96/0.74	839/548/263	103/80/51	0.012/0.016/0.020	1.2/2.0/2.0	0.004/0.008/0.010	0.0085/0.0092/0.0096	0.04/0.05/0.05	1 x M3	1.1
45	4.1	15000	4.79/2.95	2535/617	268/166	0.012/0.020	1.2/2.0	0.004/0.008	0.0335/0.0352	0.13/0.14	1 x M4	2.2
100	8.9	15000	5.97/4.94	2061/1102	263/194	0.016/0.020	1.2/2.0	0.006/0.010	0.0789/0.0854	0.13/0.15	1 x M4	2.2

Transmissible torque T [Nm]

Size	\varnothing mm																				
	\varnothing inch																				
	3	4	5	6	7	8	9	10	11	12	13	14	15	16	17	18	19	20	21	22	24
	0.118	0.157	0.197	0.236	0.276	0.315	0.354	0.394	0.433	0.472	0.512	0.551	0.591	0.630	0.670	0.707	0.748	0.787	0.827	0.866	0.945
4	0.4	0.4	0.4	0.4	0.4	0.4	---	---	---	---	---	---	---	---	---	---	---	---	---	---	---
9	0.4	0.4	0.4	0.4	0.4	0.4	---	---	---	---	---	---	---	---	---	---	---	---	---	---	---
15	1.1	1.3	1.3	1.3	1.3	1.3	1.3	1.3	---	---	---	---	---	---	---	---	---	---	---	---	---
20	1.3	1.7	1.8	1.8	1.8	1.8	1.8	1.8	1.8	1.8	1.8	1.8	---	---	---	---	---	---	---	---	---
45	---	---	4.1	4.1	4.1	4.1	4.1	4.1	4.1	4.1	4.1	4.1	4.1	4.1	4.1	---	---	---	---	---	---
100	---	---	5.2	5.9	6.6	7.7	8.9	8.9	8.9	8.9	8.9	8.9	8.9	8.9	8.9	8.9	8.9	8.9	8.9	8.9	8.9

Dimensions

- d_{1min} = Min. bore diameter
 d_{1max} = Max. bore diameter
 d_{1kmin} = Min. bore diameter with keyway acc. to DIN 6885-1
 d_{1kmax} = Max. bore diameter with keyway acc. to DIN 6885-1
 C_1 = Guided length in hub boring
 D_1 = Outer diameter hub
 D_4 = Outer diameter hub
 H = Clearance diameter
 I = Distance between center screw hole and hub end
 K = Distance shaft axis - clamping screw axis
 L = Total length
 L_5 = Expanding mandrel length



Dimensions

Size	d_1 min-max Without keyway	d_{1k} min-max With keyway	C_1	D_1	D_4	H	I	K	L	L_5
	inch	inch								
4	0.118 - 0.315	0.236 - 0.315	0.276	0.630	0.315	0.709	0.094	0.197	1.142/1.220/1.378	0.315
9	0.118 - 0.315	0.236 - 0.315	0.276	0.630	0.315	0.709	0.094	0.197	1.181/1.299/1.457	0.315
15	0.118 - 0.394	0.236 - 0.394	0.354	0.787	0.394	0.827	0.118	0.276	1.457/1.614	0.472
20	0.118 - 0.551	0.236 - 0.551	0.433	0.984	0.394	1.063	0.138	0.354	1.614/1.850/2.008	0.472
45	0.197 - 0.669	0.236 - 0.669	0.512	1.299	0.551	1.339	0.177	0.472	2.047/2.402	0.63
100	0.197 - 0.945	0.236 - 0.945	0.551	1.575	0.630	1.654	0.189	0.630	2.402/2.795	0.787

Transmission of the couplings transmissible torque T can not longer be guaranteed for certain with borings $< d_{min}$. Types with borings $< d_{min}$, however, can be supplied. Moment of inertia and weight (mass) are calculated with reference to the largest bore size.

Characteristics

- Metal bellows made of stainless steel, hubs made of aluminum
- The shaft tolerance should be within the fit tolerance "g6" or "h7"
- The contact surfaces have to be free from oil and grease
- Optional special design in stainless steel
- For the bore tolerances we recommend fit tolerance H7

The torque values shown in the technical data tables can only be safely transmitted if all instructions are followed.

Ordering example: DKN/S

Series Size	Length L	Bore diameter d_1	Further details*
DKN/S 20	1.614	0.236	*

* Keyway or stainless steel

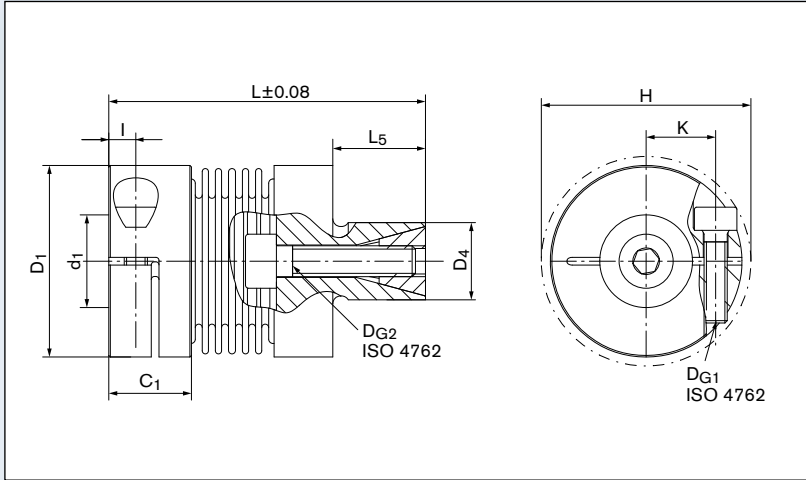

Sectional view DKN/S

Technical Data

- T = Transmissible torque at given T_A
- n_{max} = Max. rotation speed
- C_{Tdyn} = Dynamic torsional stiffness
- C_r = Radial spring stiffness
- C_a = Axial spring stiffness
- ΔK_a = Max. permissible axial misalignment
- ΔK_w = Max. permissible angular misalignment
- ΔK_r = Max. permissible radial misalignment
- J = Total moment of inertia
- Gw = Weight
- DG1 = Thread
- TA1 = Tightened torque of clamping screw DG1
- DG2 = Thread diameter
- TA2 = Tightened torque of clamping screw DG2

Technical Data

Size	T	n_{max}	C_{Tdyn}	C_r	C_a	ΔK_a	ΔK_w	ΔK_r	J	Gw	DG1	TA1	DG2	TA2
	ft-lbs	rpm	10 ³ ft-lbs/rad	lbs/inch	lbs/inch	inch	Degree	inch	lbs-in ²	lbs	mm	ft-lbs	mm	ft-lbs
4	0.4	15000	0.184/0.140/0.111	731/308/148	103/74/63	0.008/0.012/0.016	1.2/2.0/2.0	0.004/0.006/0.008	0.0010	0.015/0.018/0.020	1 x M2	0.2	1 x M3	1.3
9	0.8	15000	0.369/0.280/0.221	1068/468/240	206/154/126	0.008/0.012/0.016	1.2/2.0/2.0	0.004/0.006/0.008	0.0010	0.020/0.022/0.022	1 x M2	0.2	1 x M3	1.3
15	1.3	15000	0.553/0.516	794/463	131/69	0.010/0.016	1.2/2.0	0.004/0.006	0.0038/0.0041	0.035/0.037	1 x M2.5	0.6	1 x M4	2.2
20	1.8	15000	1.106/0.959/0.738	839/548/263	103/80/51	0.012/0.016/0.020	1.2/2.0/2.0	0.004/0.008/0.010	0.0072/0.0079/0.0085	0.053/0.060/0.062	1 x M3	1.1	1 x M4	2.2
45	4.1	15000	4.794/2.950	2535/617	268/166	0.012/0.020	1.2/2.0	0.004/0.008	0.0273/0.0294	0.141/0.154	1 x M4	2.2	1 x M5	3.0
100	9.0	15000	5.974/4.942	2061/1102	263/194	0.016/0.020	1.2/2.0	0.006/0.010	0.0782/0.0875	0.154/0.192	1 x M4	2.2	1 x M6	4.4

Transmissible torque T [Nm]

Size	Ø mm																				
	Ø inch																				
	3	4	5	6	7	8	9	10	11	12	13	14	15	16	17	18	19	20	21	22	24
	0.118	0.157	0.197	0.236	0.276	0.315	0.354	0.394	0.433	0.472	0.512	0.551	0.591	0.630	0.670	0.707	0.748	0.787	0.827	0.866	0.945
4	0.4	0.4	0.4	0.4	0.4	0.4	---	---	---	---	---	---	---	---	---	---	---	---	---	---	---
9	0.4	0.4	0.4	0.4	0.4	0.4	---	---	---	---	---	---	---	---	---	---	---	---	---	---	---
15	1.1	1.3	1.3	1.3	1.3	1.3	1.3	1.3	---	---	---	---	---	---	---	---	---	---	---	---	---
20	1.3	1.7	1.8	1.8	1.8	1.8	1.8	1.8	1.8	1.8	1.8	1.8	---	---	---	---	---	---	---	---	---
45	---	---	4.1	4.1	4.1	4.1	4.1	4.1	4.1	4.1	4.1	4.1	4.1	4.1	4.1	---	---	---	---	---	---
100	---	---	5.2	5.9	6.6	7.7	9	9	9	9	9	9	9	9	9	9	9	9	9	9	9

Dimensions

d_1 ; d_{2min}	= Min. bore diameter
d_1 ; d_{2max}	= Max. bore diameter
d_{1k} ; d_{2kmin}	= Min. bore diameter with keyway acc. to DIN 6885-1
d_{1k} ; d_{2kmax}	= Max. bore diameter with keyway acc. to DIN 6885-1
C_1	= Guided length in hub boring
D_1	= Outer diameter hub
H	= Clearance diameter
I	= Distance between center screw hole and hub end
K	= Distance shaft axis - clamping screw axis
L	= Total length
L_6	= Length of basic part
L_7	= Body length until bellow beginning or plug connection
V	= Preload distance



Dimensions

Size	d_1 min-max Without keyway	d_2 min-max Without keyway	d_{1k} min-max With keyway	d_{2k} min-max With keyway	C_1	D_1	H	I	K	L	L_6	L_7	V
	inch												
0.4	0.118 - 0.315	0.118 - 0.236	---	---	0.276	0.630	0.669	0.094	0.197	1.024/1.102/1.260	0.787/0.866/1.024	0.217	0.016
0.9	0.118 - 0.315	0.118 - 0.236	---	---	0.276	0.630	0.669	0.094	0.197	1.063/1.181/1.339	0.787/0.866/1.024	0.217	0.016
1.5	0.118 - 0.394	0.118 - 0.394	0.236 - 0.394	---	0.335	0.787	0.846	0.118	0.276	1.260/1.417	0.906/1.063	0.315	0.020
2	0.118 - 0.551	0.118 - 0.472	0.236 - 0.551	0.236 - 0.394	0.433	0.984	1.063	0.138	0.354	1.457/1.693/1.850	1.102/1.339/1.496	0.315	0.020
4.5	0.197 - 0.669	0.197 - 0.630	0.236 - 0.669	0.236 - 0.472	0.512	1.299	1.358	0.177	0.453	1.929/2.244	1.417/1.732	0.453	0.028
10	0.197 - 0.945	0.197 - 0.787	0.236 - 0.945	0.236 - 0.630	0.551	1.575	1.634	0.189	0.610	2.165/2.598	1.654/2.087	0.433	0.039
18	0.394 - 1.024	0.315 - 0.827	0.394 - 1.024	0.315 - 0.669	0.650	1.772	1.850	0.217	0.689	2.323/2.638	1.535/1.850	0.689	0.020
30	0.394 - 1.181	0.394 - 0.984	0.394 - 1.181	0.394 - 0.866	0.827	2.165	2.224	0.295	0.787	2.756/3.071	1.890/2.205	0.748	0.020
60	0.551 - 1.339	0.472 - 1.260	0.551 - 1.339	0.472 - 1.181	0.925	2.520	2.618	0.354	0.886	3.346/3.780	2.461/2.894	0.787	0.020
150	0.669 - 1.654	0.591 - 1.575	0.669 - 1.654	0.591 - 1.496	1.083	3.150	3.268	0.394	1.102	3.740/4.213	2.795/3.268	0.866	0.020
300	0.945 - 2.362	0.945 - 2.205	0.945 - 2.362	0.945 - 1.732	1.299	4.331	4.331	0.492	1.535	4.409/4.843	2.835/3.307	1.476	0.020
500	1.378 - 2.520	1.378 - 2.520	1.378 - 2.520	1.378 - 1.969	1.614	4.685	4.685	0.591	1.693	5.276/5.709	3.583/4.016	1.594	0.020

Transmission of the couplings transmissible torque T can not longer be guaranteed for certain with borings $< d_{min}$. Types with borings $< d_{min}$, however, can be supplied. Moment of inertia and weight (mass) are calculated with reference to the largest bore size.

Characteristics / Series PKA with clamping hub

- Metal bellows made of stainless steel, hubs made of aluminum
- The shaft tolerance should be within the fit tolerance "g6" or "h7"
- High power performance
- The contact surfaces have to be free from oil and grease
- Axial pluggable

The torque values shown in the technical data tables can only be safely transmitted if all instructions are followed.

Ordering example: PKA

Series Size	Length L	Bore diameter d_1	Bore diameter d_2	Position	Further details*
PKA 150	3.740	1.181	1.377	D	*

C = Single position D = Multi position * Keyway

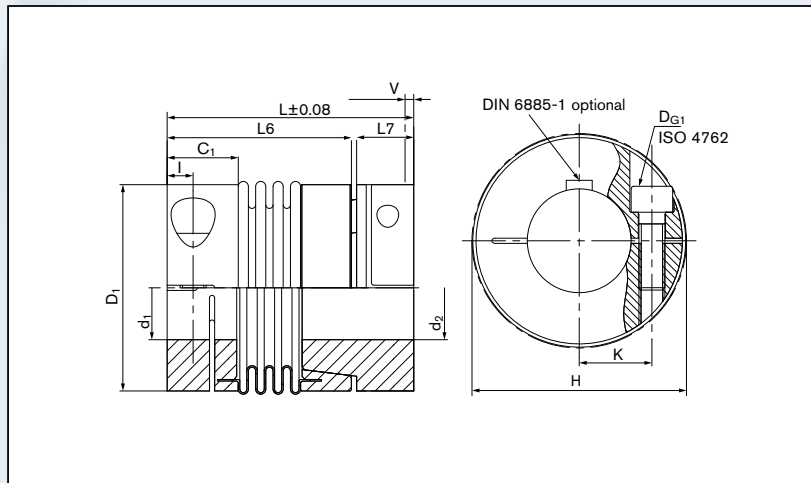

Technical Data

- T** = Transmissible torque at given T_A
- n_{max}** = Max. rotation speed
- C_{Tdyn}** = Dynamic torsional stiffness
- C_r** = Radial spring stiffness
- C_a** = Axial spring stiffness
- ΔK_a** = Max. permissible axial misalignment
- ΔK_w** = Max. permissible angular misalignment
- ΔK_r** = Max. permissible radial misalignment
- J** = Total moment of inertia
- Gw** = Weight
- D_{G1}** = Thread
- T_{A1}** = Tightened torque of clamping screw D_{G1}

Sectional view PKA

Technical Data

Size	T	n_{max}	C_{Tdyn}	C_r	C_a	ΔK_a	ΔK_w	ΔK_r	J	Gw	D _{G1}	T _{A1}
	ft-lbs	rpm	10 ³ ft-lbs/rad	lbs/inch		inch	Degree	inch	lbs-in ²	lbs	mm	ft-lbs
0.4	0.4	15000	0.18/0.14/0.11	731/308/148	103/74/63	0.008/0.012/0.016	1.2/2.0/2.0	0.004/0.006/0.008	0.0010	0.02	1 x M2	0.22
0.9	0.8	15000	0.37/0.28/0.22	1068/468/240	206/154/126	0.008/0.012/0.016	1.2/2.0/2.0	0.004/0.006/0.008	0.0014	0.02	1 x M2	0.44
1.5	1.3	15000	0.55/0.52	794/463	131/69	0.010/0.016	1.2/2.0	0.004/0.006	0.0034/0.0038	0.03/0.04	1 x M2.5	0.59
2	1.8	15000	1.11/0.96/0.74	839/548/263	103/80/51	0.012/0.016/0.020	1.2/2.0/2.0	0.004/0.008/0.010	0.0096/0.0103/0.0106	0.06/0.07/0.07	1 x M3	1.11
4.5	4.1	15000	4.79/2.95	2535/617	268/166	0.012/0.020	1.2/2.0	0.004/0.008	0.0383/0.0400	0.15/0.16	1 x M4	2.21
10	8.9	15000	5.97/4.94	2061/1102	263/194	0.016/0.020	1.2/2.0	0.006/0.010	0.0871/0.0936	0.21/0.24	1 x M4	2.21
18	16.2	12700	5.90/4.43	1142/485	286/228	0.016/0.020	1.2/1.5	0.006/0.008	0.1647/0.1989	0.34/0.37	1 x M5	4.43
30	26.6	10200	25.81/18.44	4111/1256	286/171	0.016/0.020	1.0/1.5	0.004/0.008	0.4558/0.4917	0.62/0.66	1 x M6	8.85
60	55.3	8600	55.32/36.88	6281/1884	514/314	0.016/0.020	1.0/1.5	0.004/0.008	1.1030/1.1372	1.06/1.12	1 x M8	22.13
150	132.8	6800	110.64/73.76	11420/3426	857/485	0.016/0.020	1.0/1.5	0.008	2.8324/2.9349	1.77/1.88	1 x M10	62.69
300	265.5	5900	368.79/206.52	35973/8565	1599/857	0.016/0.020	1.0/1.5	0.008	11.2727/11.8023	3.77/3.90	1 x M12	88.51
500	442.5	4900	501.55/228.65	50248/5710	571/485	0.020/0.039	1.0/1.5	0.008	19.0839/20.0065	5.27/5.49	1 x M14	140.14

Transmissible torque T [Nm]

Size	Ø mm																																		
	3	4	5	6	7	8	9	10	11	12	13	14	15	16	17	18	19	20	21	22	24	25	28	30	35	40	45	50	55	60	64				
	0.118	0.157	0.197	0.236	0.276	0.315	0.354	0.394	0.433	0.472	0.512	0.551	0.591	0.630	0.670	0.707	0.748	0.787	0.827	0.866	0.945	0.984	1.102	1.181	1.378	1.575	1.772	1.989	2.165	2.362	2.520				
0.4	0.4	0.4	0.4	0.4	0.4	0.4	---	---	---	---	---	---	---	---	---	---	---	---	---	---	---	---	---	---	---	---	---	---	---	---	---	---			
0.9	0.4	0.4	0.4	0.4	0.4	0.4	---	---	---	---	---	---	---	---	---	---	---	---	---	---	---	---	---	---	---	---	---	---	---	---	---	---			
1.5	1.1	1.3	1.3	1.3	1.3	1.3	1.3	1.3	---	---	---	---	---	---	---	---	---	---	---	---	---	---	---	---	---	---	---	---	---	---	---	---			
2	1.3	1.7	1.8	1.8	1.8	1.8	1.8	1.8	1.8	1.8	1.8	1.8	---	---	---	---	---	---	---	---	---	---	---	---	---	---	---	---	---	---	---	---			
4.5	---	---	4.1	4.1	4.1	4.1	4.1	4.1	4.1	4.1	4.1	4.1	4.1	4.1	4.1	---	---	---	---	---	---	---	---	---	---	---	---	---	---	---	---	---			
10	---	---	5.2	5.9	6.6	7.7	8.9	8.9	8.9	8.9	8.9	8.9	8.9	8.9	8.9	8.9	8.9	8.9	8.9	8.9	8.9	---	---	---	---	---	---	---	---	---	---	---			
18	---	---	---	---	---	---	13.3	14.8	16.2	16.2	16.2	16.2	16.2	16.2	16.2	16.2	16.2	16.2	16.2	16.2	16.2	16.2	16.2	---	---	---	---	---	---	---	---	---			
30	---	---	---	---	---	---	---	26.6	26.6	26.6	26.6	26.6	26.6	26.6	26.6	26.6	26.6	26.6	26.6	26.6	26.6	26.6	26.6	26.6	26.6	26.6	---	---	---	---	---	---			
60	---	---	---	---	---	---	---	---	---	55.3	55.3	55.3	55.3	55.3	55.3	55.3	55.3	55.3	55.3	55.3	55.3	55.3	55.3	55.3	55.3	55.3	55.3	---	---	---	---	---			
150	---	---	---	---	---	---	---	---	---	---	---	---	---	132.8	132.8	132.8	132.8	132.8	132.8	132.8	132.8	132.8	132.8	132.8	132.8	132.8	132.8	---	---	---	---	---			
300	---	---	---	---	---	---	---	---	---	---	---	---	---	---	---	---	---	---	---	---	---	---	---	---	---	---	---	265.5	265.5	265.5	265.5	265.5	---	---	
500	---	---	---	---	---	---	---	---	---	---	---	---	---	---	---	---	---	---	---	---	---	---	---	---	---	---	---	---	442.5	442.5	442.5	442.5	442.5	442.5	---

Dimensions

- $d_1; d_{2min}$ = Min. bore diameter
 $d_1; d_{2max}$ = Max. bore diameter
 C_1 = Guided length in hub boring d_1
 C_2 = Guided length in hub boring d_2
 D_1 = Outer diameter hub
 H = Clearance diameter
 L = Total length
 L_6 = Length of basic part
 L_7 = Body length until bellow beginning or plug connection
 V = Preload distance



Dimensions

Size	$d_1; d_2$ min-max	C_1	C_2	D_1	H	L	L_6	L_7	V
	Without keyway								
18	0.394 - 0.630	0.630	1.024	1.772	1.772	2.283/2.598	1.535/1.850	0.669	0.02 - 0.04
30	0.472 - 0.945	0.787	1.260	2.165	2.205	2.677/2.992	1.850/2.165	0.748	0.02 - 0.04
60	0.472 - 1.260	0.866	1.457	2.598	2.598	3.110/3.504	1.654/2.047	0.866	0.02 - 0.06
150	0.591 - 1.575	1.102	1.772	3.150	3.228	3.819/4.291	2.047/2.520	1.102	0.02 - 0.06
300	0.945 - 2.205	1.496	1.811	4.331	4.331	4.449/4.882	3.091/3.524	1.299	0.02 - 0.06
500	1.181 - 2.362	1.654	2.441	4.685	4.803	5.197/5.709	3.583/4.094	1.496	0.02 - 0.08

Transmission of the couplings transmissible torque T can not longer be guaranteed for certain with borings $< d_{min}$. Types with borings $< d_{min}$, however, can be supplied. Moment of inertia and weight (mass) are calculated with reference to the largest bore size.

Characteristics / Series PKB with locking ring

- Axial mountable from in- and outside
- Metal bellows made of stainless steel, hubs made of aluminum
- The shaft tolerance should be within the fit tolerance "g6" or "h7"
- High power performance
- The contact surfaces have to be free from oil and grease
- Axial pluggable

The torque values shown in the technical data tables can only be safely transmitted if all instructions are followed.

Ordering example: PKB

Series Size	Length L	Bore diameter d_1	Bore diameter d_2	Position	Further details*
PKB 150	3.819	1.181	1.377	C	*

C = Single position D = Multi position * Keyway

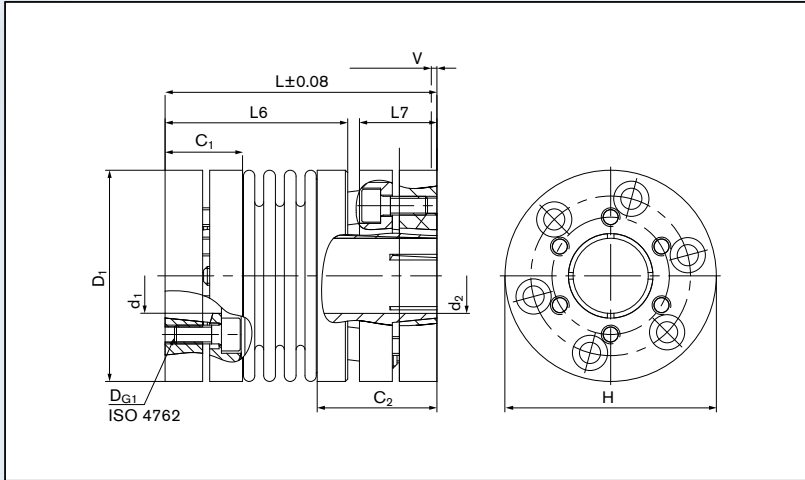

Sectional view PKB

Technical Data

- T** = Transmissible torque at given T_A
- n_{max}** = Max. rotation speed
- C_{Tdyn}** = Dynamic torsional stiffness
- C_r** = Radial spring stiffness
- C_a** = Axial spring stiffness
- ΔK_a** = Max. permissible axial misalignment
- ΔK_w** = Max. permissible angular misalignment
- ΔK_r** = Max. permissible radial misalignment
- J** = Total moment of inertia
- Gw** = Weight
- D_{G1}** = Thread
- T_{A1}** = Tightened torque of clamping screw D_{G1}

Technical Data

Size	T	n_{max}	C_{Tdyn}	C_r	C_a	ΔK_a	ΔK_w	ΔK_r	J	Gw	D_{G1}	T_{A1}
	ft-lbs	rpm	10 ³ ft-lbs/rad	lbs/inch		inch	Degree	inch	lbs-in ²	lbs	mm	ft-lbs
18	16.2	12700	6	1142	286	0.020	1.5	0.008	0.251/0.263	0.56/0.58	6 x M4	1.5
30	26.6	10200	26/18	4111/1256	286/171	0.016/0.020	1.0/1.5	0.004/0.008	0.681/0.717	0.95/0.99	6 x M4	1.8
60	55.3	8600	55/37	6281/1884	514/314	0.016/0.020	1.0/1.5	0.004/0.008	1.548/1.637	1.45/1.51	6 x M5	3.0
150	132.8	6800	111/74	11420/3426	857/485	0.016/0.020	1.0/1.5	0.008	4.271/4.497	2.67/2.78	6 x M5	5.9
300	265.5	5900	369/207	35973/8565	1599/857	0.016/0.020	1.0/1.5	0.008	18.141/18.676	6.71/6.84	6 x M8	11.8
500	442.5	4900	502/229	50248/5710	571/485	0.020/0.039	1.0/1.5	0.008	26.533/27.455	7.76/7.96	6 x M8	14.8

Transmissible torque T [Nm]

Size	\varnothing mm																			
	10	12	14	15	16	18	20	22	24	26	30	32	35	38	40	44	48	50	55	60
	\varnothing inch																			
	0.394	0.472	0.551	0.591	0.630	0.707	0.787	0.866	0.945	1.023	1.181	1.260	1.378	1.496	1.575	1.732	1.890	1.989	2.165	2.362
18	16.2	16.2	16.2	16.2	16.2	---	---	---	---	---	---	---	---	---	---	---	---	---	---	---
30	---	26.6	26.6	26.6	26.6	26.6	26.6	26.6	26.6	---	---	---	---	---	---	---	---	---	---	---
60	---	24.3	49.4	55.3	55.3	55.3	55.3	55.3	55.3	55.3	55.3	55.3	---	---	---	---	---	---	---	---
150	---	---	---	70.8	90.7	115.1	132.8	132.8	132.8	132.8	132.8	132.8	132.8	132.8	---	---	---	---	---	---
300	---	---	---	---	---	---	---	---	168.9	199.1	265.5	265.5	265.5	265.5	265.5	265.5	265.5	265.5	265.5	265.5
500	---	---	---	---	---	---	---	---	---	---	310.5	355.5	428.5	442.5	442.5	442.5	442.5	442.5	442.5	442.5

Dimensions

$d_1; d_{2min}$	= Min. bore diameter
$d_1; d_{2max}$	= Max. bore diameter
$d_{1k}; d_{2kmin}$	= Min. bore diameter with keyway acc. to DIN 6885-1
$d_{1k}; d_{2kmax}$	= Max. bore diameter with keyway acc. to DIN 6885-1
C_1	= Guided length in hub boring d_1
C_2	= Guided length in hub boring d_2
D_1	= Outer diameter hub
H	= Clearance diameter
I	= Distance between center screw hole and hub end
K	= Distance shaft axis - clamping screw axis
L	= Total length
L_6	= Length of basic part



Dimensions

Size	d_1 min-max	d_2 min-max	d_{1k} min-max	d_{2k} min-max	C_1	C_2	D_1	H	I	K	L	L_6
	Without keyway	With keyway	With keyway	Without keyway								
	inch	inch	inch		inch		inch	inch		inch	inch	
2	0.118 - 0.551	0.118 - 0.354	0.236 - 0.551	0.236 - 0.354	0.433	0.453	0.984	1.102	0.157	0.354	1.535	1.024
4.5	0.236 - 0.669	0.236 - 0.630	0.236 - 0.669	0.236 - 0.630	0.512	0.512	1.299	1.378	0.197	0.472	1.870	1.299
10	0.236 - 0.945	0.236 - 0.866	0.236 - 0.945	0.236 - 0.866	0.551	0.512	1.575	1.654	0.197	0.630	2.106	1.535
18	0.315 - 1.024	0.315 - 0.866	0.315 - 1.024	0.315 - 0.866	0.787	0.728	1.772	1.890	0.236	0.709	2.776	1.969
30	0.394 - 1.181	0.394 - 1.102	0.394 - 1.181	0.394 - 1.102	0.984	0.866	2.165	2.205	0.315	0.787	2.835	1.890
60	0.394 - 1.378	0.394 - 1.181	0.394 - 1.378	0.394 - 1.181	1.142	1.142	2.598	2.638	0.394	0.945	3.484	2.244
80	0.551 - 1.654	0.551 - 1.654	0.551 - 1.654	0.551 - 1.654	1.339	1.299	3.150	3.346	0.472	1.102	4.035	2.638
150	0.551 - 1.654	0.551 - 1.654	0.551 - 1.654	0.551 - 1.654	1.339	1.299	3.150	3.346	0.472	1.102	4.035	2.638

Transmission of the couplings transmissible torque T can not longer be guaranteed for certain with borings $< d_{min}$. Types with borings $< d_{min}$, however, can be supplied. Moment of inertia and weight (mass) are calculated with reference to the largest bore size.

Characteristics

- Metal bellows made of stainless steel, hubs made of aluminum
- The shaft tolerance should be within the fit tolerance "g6" or "h7"
- The contact surfaces have to be free from oil and grease
- Optional special design in stainless steel

The torque values shown in the technical data tables can only be safely transmitted if all instructions are followed.

Ordering example: PKN

Series Size	Bore diameter d_1	Bore diameter d_2	Further details*
PKN 150	1.181	1.377	*

* Keyway or stainless steel

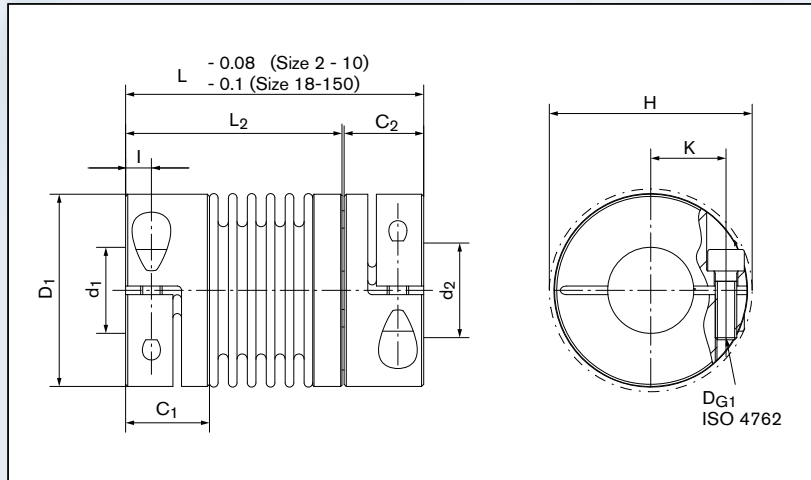

Sectional view PKN

Technical Data

- T = Transmissible torque at given T_A
- n_{max} = Max. rotation speed
- C_{Tdyn} = Dynamic torsional stiffness
- C_r = Radial spring stiffness
- C_a = Axial spring stiffness
- ΔK_a = Max. permissible axial misalignment
- ΔK_w = Max. permissible angular misalignment
- ΔK_r = Max. permissible radial misalignment
- J = Total moment of inertia
- G_w = Weight
- D_{G1} = Thread
- T_{A1} = Tightened torque of clamping screw D_{G1}

Technical Data

Size	T	n_{max}	C_{Tdyn}	C_r	C_a	ΔK_a	ΔK_w	ΔK_r	J	G_w	D_{G1}	T_{A1}
	ft-lbs	rpm	10^3 ft-lbs/rad	lbs/inch	inch	Degree	inch	lbs-in ²	lbs	mm	ft-lbs	
2	1.8	22900	1.1	839	103	0.016	1.2	0.008	0.07	0.07	1 x M3	1.1
4.5	4.1	17600	4.8	2535	268	0.012	1.2	0.004	0.10	0.15	1 x M4	2.2
10	9	14100	5.9	2061	263	0.016	1.2	0.006	0.14	0.20	1 x M4	2.2
18	16	12700	5.9	286	1142	0.020	1.5	0.008	0.18	0.36	1 x M5	4.4
30	27	10200	26	286	4111	0.016	1.0	0.004	0.42	0.62	1 x M6	9
60	55	8600	55	514	6281	0.016	1.0	0.004	1.11	1.10	1 x M8	22
80	70	6800	96	457	6852	0.016	1.0	0.008	3.02	1.90	1 x M10	44
150	133	6800	111	857	11420	0.016	1.0	0.008	3.02	1.90	1 x M10	63

Transmissible torque T [Nm]

Size	\emptyset mm																				
	3	4	5	6	8	10	12	14	15	18	20	21	24	27	28	30	32	35	36	38	41
	\emptyset inch																				
	0.118	0.157	0.197	0.236	0.315	0.394	0.472	0.551	0.591	0.707	0.787	0.827	0.945	1.063	1.102	1.181	1.260	1.378	1.417	1.496	1.614
2	1.3	1.7	1.8	1.8	1.8	---	---	---	---	---	---	---	---	---	---	---	---	---	---	---	---
4.5	---	---	4.1	4.1	4.1	4.1	4.1	4.1	---	---	---	---	---	---	---	---	---	---	---	---	---
10	---	---	---	5.9	8	9	9	9	9	9	9	---	---	---	---	---	---	---	---	---	---
18	---	---	---	---	---	13	16	16	16	16	16	16	---	---	---	---	---	---	---	---	---
30	---	---	---	---	---	27	27	27	27	27	27	27	27	27	---	---	---	---	---	---	---
60	---	---	---	---	---	---	---	55	55	55	55	55	55	55	55	---	---	---	---	---	---
80	---	---	---	---	---	---	---	70	70	70	70	70	70	70	70	70	70	70	70	70	70
150	---	---	---	---	---	---	---	133	133	133	133	133	133	133	133	133	133	133	133	133	133

Dimensions

- $d_1; d_{2min}$ = Min. bore diameter
 $d_1; d_{2max}$ = Max. bore diameter
 $d_{1k}; d_{2kmin}$ = Min. bore diameter with keyway acc. to DIN 6885-1
 $d_{1k}; d_{2kmax}$ = Max. bore diameter with keyway acc. to DIN 6885-1
 C_1 = Guided length in hub boring d_1
 D_1 = Outer diameter hub
 H = Clearance diameter
 I = Distance between center screw hole and hub end
 K = Distance shaft axis - clamping screw axis
 L = Total length



Dimensions

Size	$d_1; d_2$ min-max		$d_{1k}; d_{2k}$ min-max		C_1	D_1	H	I	K	L
	Without keyway	With keyway								
	inch	inch	inch	inch						
18	0.315 - 1.024	0.315 - 1.024	0.756	1.772	1.850	0.236	0.709	2.480		
30	0.394 - 1.181	0.394 - 1.181	0.949	2.165	2.205	0.315	0.787	2.559		
60	0.472 - 1.378	0.472 - 1.378	1.126	2.520	2.638	0.394	0.945	3.071		
80	0.551 - 1.654	0.551 - 1.654	1.276	3.150	3.307	0.472	1.102	3.543		
150	0.551 - 1.654	0.551 - 1.654	1.276	3.150	3.307	0.472	1.102	3.543		
200	0.866 - 1.811	0.866 - 1.811	1.453	3.543	3.661	0.512	1.220	3.898		
300	0.945 - 2.362	0.945 - 2.362	1.453	4.331	4.331	0.512	1.535	4.094		
500	1.378 - 2.520	1.378 - 2.520	1.591	4.685	4.803	0.591	1.693	4.370		

Transmission of the couplings transmissible torque T can not longer be guaranteed for certain with borings $< d_{min}$. Types with borings $< d_{min}$, however, can be supplied. Moment of inertia and weight (mass) are calculated with reference to the largest bore size.

Characteristics

- Metal bellows made of stainless steel, hubs made of aluminum
- The shaft tolerance should be within the fit tolerance "g6" or "h7"
- The contact surfaces have to be free from oil and grease
- Optional special design in stainless steel

The torque values shown in the technical data tables can only be safely transmitted if all instructions are followed.

Ordering example: AKN

Series Size	Bore diameter d_1	Bore diameter d_2	Further details*
AKN 150	1.181	1.377	*

* Keyway or stainless steel

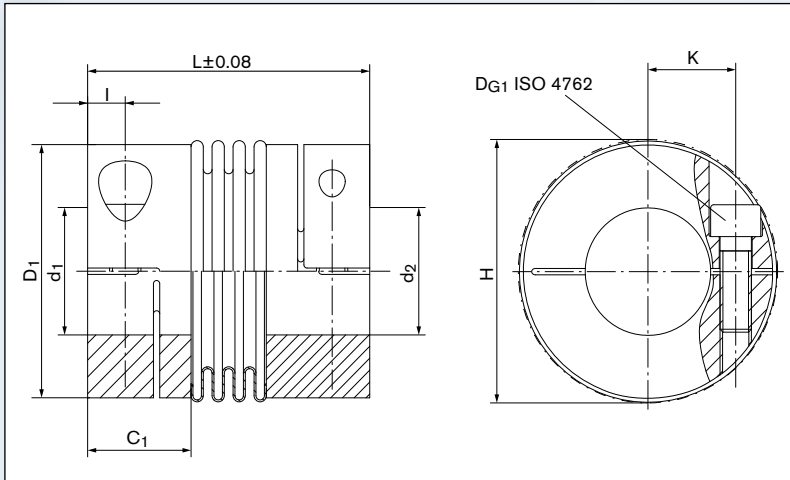

Sectional view AKN

Technical Data

- T** = Transmissible torque at given T_A
- n_{max}** = Max. rotation speed
- C_{Tdyn}** = Dynamic torsional stiffness
- C_r** = Radial spring stiffness
- C_a** = Axial spring stiffness
- ΔK_a** = Max. permissible axial misalignment
- ΔK_w** = Max. permissible angular misalignment
- ΔK_r** = Max. permissible radial misalignment
- J** = Total moment of inertia
- Gw** = Weight
- D_{G1}** = Thread
- T_{A1}** = Tightened torque of clamping screw D_{G1}

Technical Data

Size	T	n_{max}	C_{Tdyn}	C_r	C_a	ΔK_a	ΔK_w	ΔK_r	J	Gw	D_{G1}	T_{A1}
	ft-lbs	rpm	10^3 ft-lbs/rad	lbs/inch		inch	Degree	inch	lbs-in ²	lbs	mm	ft-lbs
18	16	12700	6	1142	286	0.02	1.5	0.008	0.2	0.29	1 x M5	4.5
30	27	10200	26	4111	286	0.016	1.0	0.004	0.4	0.54	1 x M6	9
60	55	8600	55	6281	514	0.016	1.0	0.004	1.0	0.9	1 x M8	22
80	70	6800	96	6852	457	0.016	1.0	0.008	3.0	1.6	1 x M10	45
150	133	6800	111	11420	857	0.016	1.0	0.008	3.0	1.6	1 x M10	63
200	177	6300	125	14276	857	0.016	1.0	0.008	4.9	2.3	1 x M12	74
300	266	5900	369	35974	1599	0.016	1.0	0.008	10.3	3.2	1 x M12	86
500	443	4900	502	50250	571	0.02	1.0	0.008	16.1	4.3	1 x M14	140

Transmissible torque T [Nm]

Size	\varnothing mm																				
	8	9	10	11	12	13	15	16	18	20	22	25	28	30	35	40	45	50	55	60	64
	\varnothing inch																				
	0.315	0.354	0.394	0.433	0.472	0.512	0.591	0.630	0.707	0.787	0.866	0.984	1.102	1.181	1.378	1.575	1.772	1.989	2.165	2.362	2.520
18	13	15	16	16	16	16	16	16	16	16	16	16	---	---	---	---	---	---	---	---	---
30	---	---	27	27	27	27	27	27	27	27	27	27	27	27	---	---	---	---	---	---	---
60	---	---	---	---	55	55	55	55	55	55	55	55	55	55	55	---	---	---	---	---	---
80	---	---	---	---	---	---	70	70	70	70	70	70	70	70	70	70	---	---	---	---	---
150	---	---	---	---	---	---	133	133	133	133	133	133	133	133	133	133	---	---	---	---	---
200	---	---	---	---	---	---	---	---	---	---	177	177	177	177	177	177	177	---	---	---	---
300	---	---	---	---	---	---	---	---	---	---	---	266	266	266	266	266	266	266	266	266	---
500	---	---	---	---	---	---	---	---	---	---	---	---	---	---	443	443	443	443	443	443	443

Dimensions

- $d_1; d_{2min}$ = Min. bore diameter
 $d_1; d_{2max}$ = Max. bore diameter
 $d_{1k}; d_{2kmin}$ = Min. bore diameter with keyway acc. to DIN 6885-1
 $d_{1k}; d_{2kmax}$ = Max. bore diameter with keyway acc. to DIN 6885-1
 C_1 = Guided length in hub boring d_1
 D_1 = Outer diameter hub
 H = Clearance diameter
 I = Distance between center screw hole and hub end
 K = Distance shaft axis - clamping screw axis
 K_1 = Clamping length
 L = Total length



Dimensions

Size	$d_1; d_2$ min-max	$d_{1k}; d_{2k}$ min-max	C_1	D_1	H	I	K	K_1	L
	Without keyway	With keyway							
	inch		inch	inch	inch	inch			inch
18	0.315 - 1.024	0.315 - 1.024	0.787	1.772	1.85	0.236	0.709	0.433	2.480
30	0.394 - 1.181	0.394 - 1.181	0.984	2.165	2.205	0.315	0.787	0.591	2.559
60	0.472 - 1.378	0.472 - 1.378	1.142	2.520	2.638	0.394	0.945	0.748	3.071
80	0.551 - 1.654	0.551 - 1.654	1.339	3.150	3.307	0.472	1.102	0.827	3.543
150	0.551 - 1.654	0.551 - 1.654	1.339	3.150	3.307	0.472	1.102	0.827	3.543
200	0.866 - 1.811	0.866 - 1.811	1.496	3.543	3.661	0.512	1.220	0.945	3.898
300	0.945 - 2.362	0.945 - 2.362	1.496	4.331	4.331	0.512	1.535	0.945	4.094
500	1.378 - 2.52	1.378 - 2.520	1.614	4.685	4.803	0.591	1.693	1.083	4.370

Transmission of the couplings transmissible torque T can not longer be guaranteed for certain with borings $< d_{min}$. Types with borings $< d_{min}$, however, can be supplied. Moment of inertia and weight (mass) are calculated with reference to the largest bore size.

Characteristics

- Metal bellows made of stainless steel, hubs made of aluminum
- The shaft tolerance should be within the fit tolerance "g6" or "h7"
- The contact surfaces have to be free from oil and grease
- Optional special design in stainless steel

The torque values shown in the technical data tables can only be safely transmitted if all instructions are followed.

Ordering example: AKN-H

Series Size	Bore diameter d_1	Bore diameter d_2	Further details*
AKN-H 150	1.377	1.654	*

* Keyway or stainless steel

GERWAH® AKN-H

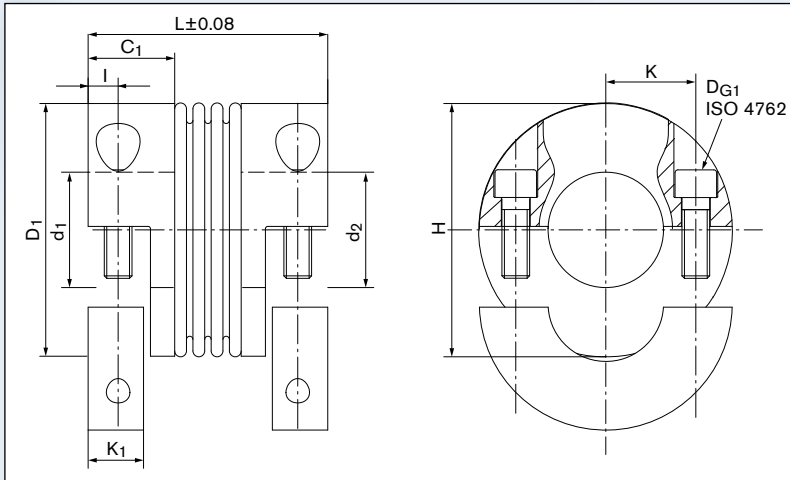

Sectional view AKN-H

Technical Data

- T** = Transmissible torque at given T_A
- n_{max}** = Max. rotation speed
- C_{Tdyn}** = Dynamic torsional stiffness
- C_r** = Radial spring stiffness
- C_a** = Axial spring stiffness
- ΔK_a** = Max. permissible axial misalignment
- ΔK_w** = Max. permissible angular misalignment
- ΔK_r** = Max. permissible radial misalignment
- J** = Total moment of inertia
- Gw** = Weight
- D_{G1}** = Thread
- T_{A1}** = Tightened torque of clamping screw D_{G1}

Technical Data

Size	T	n_{max}	C_{Tdyn}	C_r	C_a	ΔK_a	ΔK_w	ΔK_r	J	Gw	D _{G1}	T _{A1}
	ft-lbs	rpm	10 ³ ft-lbs/rad	lbs/inch		inch	Degree	inch	lbs-in ²	lbs	mm	ft-lbs
18	16	12700	6	1142	286	0.020	1.5	0.008	0.2	0.33	2 x M5	4.4
30	27	10200	26	4111	286	0.016	1.0	0.004	0.4	0.55	2 x M6	9
60	55	8600	55	6281	514	0.016	1.0	0.004	1.0	0.93	2 x M8	22
80	70	6800	96	6852	457	0.016	1.0	0.008	3.0	1.7	2 x M10	44
150	133	6800	111	11420	857	0.016	1.0	0.008	3.0	1.7	2 x M10	63
200	177	6300	125	14276	857	0.016	1.0	0.008	4.9	2.4	2 x M12	74
300	266	5900	369	35974	1599	0.016	1.0	0.008	10.3	3.3	2 x M12	89
500	443	4900	502	50250	571	0.020	1.0	0.008	16.1	4.4	2 x M14	140

Transmissible torque T [Nm]

Size	Ø mm																					
	8	9	10	11	12	14	15	18	20	22	24	25	28	30	35	40	45	50	55	60	64	
	0.315	0.354	0.394	0.433	0.472	0.551	0.591	0.707	0.787	0.866	0.945	0.984	1.102	1.181	1.378	1.575	1.772	1.989	2.165	2.362	2.520	
18	10	11	13	14	15	16	16	16	16	16	16	16	---	---	---	---	---	---	---	---	---	
30	---	---	21	22	24	27	27	27	27	27	27	27	27	27	---	---	---	---	---	---	---	
60	---	---	---	---	46	55	55	55	55	55	55	55	55	55	55	---	---	---	---	---	---	
80	---	---	---	---	---	70	70	70	70	70	70	70	70	70	70	70	---	---	---	---	---	
150	---	---	---	---	---	123	133	133	133	133	133	133	133	133	133	133	---	---	---	---	---	
200	---	---	---	---	---	---	---	---	---	177	177	177	177	177	177	177	177	---	---	---	---	
300	---	---	---	---	---	---	---	---	---	---	252	266	266	266	266	266	266	266	266	266	---	
500	---	---	---	---	---	---	---	---	---	---	---	---	---	---	---	443	443	443	443	443	443	443

Dimensions

- $d_1; d_{2min}$ = Min. bore diameter
 $d_1; d_{2max}$ = Max. bore diameter
 $d_{1k}; d_{2kmin}$ = Min. bore diameter with keyway acc. to DIN 6885-1
 $d_{1k}; d_{2kmax}$ = Max. bore diameter with keyway acc. to DIN 6885-1
 C_1 = Guided length in hub boring d_1
 D_1 = Outer diameter hub
 H = Clearance diameter
 I = Distance between center screw hole and hub end
 K = Distance shaft axis - clamping screw axis
 L = Total length

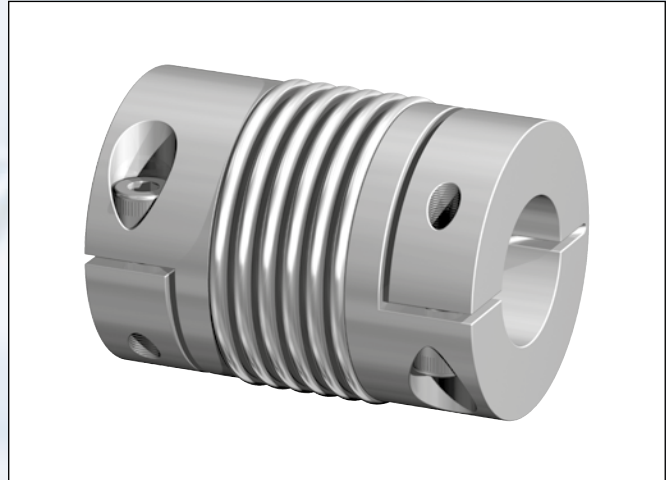

Dimensions

Size	$d_1; d_2$ min-max Without keyway	$d_{1k}; d_{2k}$ min-max With keyway	C_1	D_1	H	I	K	L
	inch							
18	0.315 - 1.024	0.315 - 1.024	0.756	1.772	1.850	0.236	0.709	2.795
30	0.394 - 1.181	0.394 - 1.181	0.949	2.165	2.205	0.315	0.787	2.874
60	0.472 - 1.378	0.472 - 1.378	1.126	2.520	2.638	0.394	0.945	3.504
80	0.551 - 1.654	0.551 - 1.654	1.276	3.150	3.307	0.472	1.102	4.055
150	0.551 - 1.654	0.551 - 1.654	1.276	3.150	3.307	0.472	1.102	4.055
200	0.866 - 1.811	0.866 - 1.811	1.453	3.543	3.661	0.512	1.220	4.449
300	0.945 - 2.362	0.945 - 2.362	1.453	4.331	4.331	0.512	1.535	4.528
500	1.378 - 2.520	1.378 - 2.520	1.591	4.685	4.803	0.591	1.693	4.803
800	1.575 - 2.953	1.575 - 2.953	1.780	5.197	5.472	0.669	1.890	5.512

Transmission of the couplings transmissible torque T can no longer be guaranteed for certain with borings $< d_{min}$. Types with borings $< d_{min}$, however, can be supplied. Moment of inertia and weight (mass) are calculated with reference to the largest bore size.

Characteristics

- Metal bellows made of stainless steel, hubs made of aluminum / hubs size 800 and larger made of steel
- The shaft tolerance should be within the fit tolerance "g6" or "h7"
- The contact surfaces have to be free from oil and grease
- Optional special design in stainless steel
- Other sizes available on request

The torque values shown in the technical data tables can only be safely transmitted if all instructions are followed.

Ordering example: AKD

Series Size	Bore diameter d_1	Bore diameter d_2	Further details*
AKD 150	1.181	1.378	*

* Keyway or stainless steel

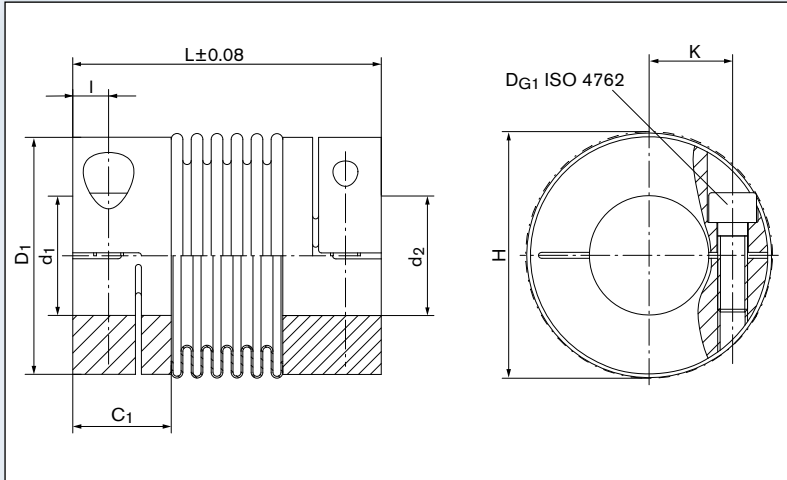

Sectional view AKD

Technical Data

- T** = Transmissible torque at given T_A
- n_{max}** = Max. rotation speed
- C_{Tdyn}** = Dynamic torsional stiffness
- C_r** = Radial spring stiffness
- C_a** = Axial spring stiffness
- ΔK_a** = Max. permissible axial misalignment
- ΔK_w** = Max. permissible angular misalignment
- ΔK_r** = Max. permissible radial misalignment
- J** = Total moment of inertia
- G_w** = Weight
- D_{G1}** = Thread
- T_{A1}** = Tightened torque of clamping screw D_{G1}

Technical Data

Size	T	n_{max}	C_{Tdyn}	C_r	C_a	ΔK_a	ΔK_w	ΔK_r	J	G _w	D _{G1}	T _{A1}
	ft-lbs	rpm	10 ³ ft-lbs/rad	lbs/inch		inch	Degree	inch	lbs-in ²	lbs	mm	ft-lbs
18	16	12700	4	485	228	0.020	1.5	0.008	0.2	0.4	2 x M5	4.4
30	27	10200	18	1256	171	0.020	1.5	0.008	0.3	0.6	2 x M6	9
60	55	8600	37	1884	314	0.020	1.5	0.008	1.0	1.0	2 x M8	22
80	70	6800	55	2284	314	0.020	1.5	0.008	3.1	2.0	2 x M10	44
150	133	6800	74	3426	485	0.020	1.5	0.008	3.1	2.0	2 x M10	63
200	177	6300	89	2570	485	0.020	1.5	0.008	5.1	3.0	2 x M12	74
300	266	5900	207	8565	857	0.020	1.5	0.008	10.9	3.0	2 x M12	89
500	443	4900	229	5710	485	0.039	1.5	0.008	16.7	5.0	2 x M14	140
800	590	5000	575	35403	571	0.138	1.5	0.014	59.8	13.0	2 x M16	184

Transmissible torque T [Nm]

Size	Ø mm Ø inch																				
	8 0.315	9 0.354	10 0.394	11 0.433	12 0.472	14 0.551	15 0.591	16 0.630	18 0.707	20 0.787	25 0.984	30 1.181	35 1.378	40 1.575	45 1.772	50 1.989	55 2.165	60 2.362	64 2.520	70 2.756	75 2.953
18	13	15	16	16	16	16	16	16	16	16	---	---	---	---	---	---	---	---	---	---	---
30	---	---	27	27	27	27	27	27	27	27	27	27	---	---	---	---	---	---	---	---	---
60	---	---	---	---	55	55	55	55	55	55	55	55	55	---	---	---	---	---	---	---	---
80	---	---	---	---	---	---	70	70	70	70	70	70	70	70	---	---	---	---	---	---	---
150	---	---	---	---	---	---	133	133	133	133	133	133	133	133	133	---	---	---	---	---	---
200	---	---	---	---	---	---	---	---	---	---	177	177	177	177	177	---	---	---	---	---	---
300	---	---	---	---	---	---	---	---	---	---	266	266	266	266	266	266	266	266	---	---	---
500	---	---	---	---	---	---	---	---	---	---	---	443	443	443	443	443	443	443	443	---	---
800	---	---	---	---	---	---	---	---	---	---	---	---	---	590	590	590	590	590	590	590	590

Dimensions

- $d_1; d_{2min}$ = Min. bore diameter
 $d_1; d_{2max}$ = Max. bore diameter
 $d_{1k}; d_{2kmin}$ = Min. bore diameter with keyway acc. to DIN 6885-1
 $d_{1k}; d_{2kmax}$ = Max. bore diameter with keyway acc. to DIN 6885-1
 C_1 = Guided length in hub boring d_1
 D_1 = Outer diameter hub
 H = Clearance diameter
 I = Distance between center screw hole and hub end
 K = Distance shaft axis - clamping screw axis
 K_1 = Clamping length
 L = Total length



Dimensions

Size	$d_1; d_2$ min-max	$d_{1k}; d_{2k}$ min-max	C_1	D_1	H	I	K	K_1	L
	Without keyway	With keyway							
	inch		inch	inch	inch	inch			inch
18	0.315 - 1.024	0.315 - 1.024	0.756	1.772	1.850	0.236	0.709	0.433	2.795
30	0.394 - 1.181	0.394 - 1.181	0.949	2.165	2.205	0.315	0.787	0.591	2.874
60	0.472 - 1.378	0.472 - 1.378	1.126	2.520	2.638	0.394	0.945	0.748	3.504
80	0.551 - 1.654	0.551 - 1.654	1.276	3.150	3.307	0.472	1.102	0.827	4.055
150	0.551 - 1.654	0.551 - 1.654	1.276	3.150	3.307	0.472	1.102	0.827	4.055
200	0.866 - 1.811	0.866 - 1.811	1.453	3.543	3.661	0.512	1.220	0.945	4.449
300	0.945 - 2.362	0.945 - 2.362	1.453	4.331	4.331	0.512	1.535	0.945	4.528
500	1.378 - 2.520	1.378 - 2.520	1.591	4.685	4.803	0.591	1.693	1.083	4.803
800	1.575 - 2.953	1.575 - 2.953	1.780	5.197	5.472	0.669	1.890	1.339	5.512

Transmission of the couplings transmissible torque T can not longer be guaranteed for certain with borings $< d_{min}$. Types with borings $< d_{min}$, however, can be supplied. Moment of inertia and weight (mass) are calculated with reference to the largest bore size.

Characteristics

- Metal bellows made of stainless steel, hubs made of aluminum / hubs size 800 and larger made of steel
- The shaft tolerance should be within the fit tolerance "g6" or "h7"
- The contact surfaces have to be free from oil and grease
- Optional special design in stainless steel
- Other sizes available on request

The torque values shown in the technical data tables can only be safely transmitted if all instructions are followed.

Ordering example: AKD-H

Series Size	Bore diameter d_1	Bore diameter d_2	Further details*
AKD-H 150	1.181	1.378	*

* Keyway or stainless steel

GERWAH® AKD-H

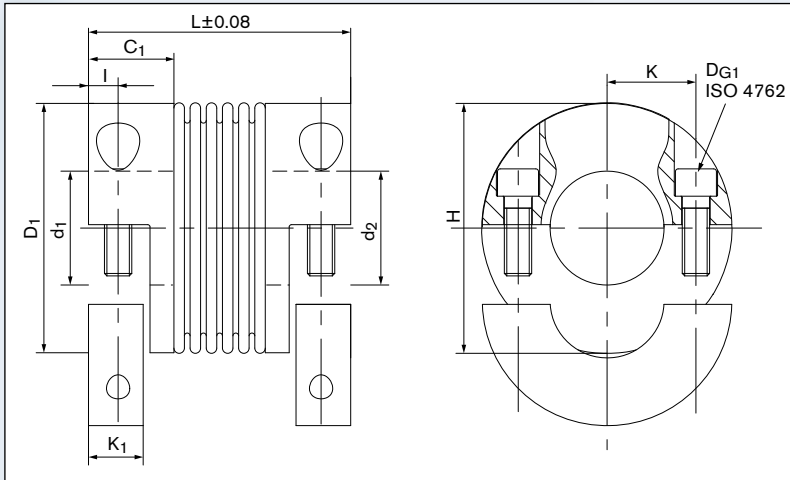

Sectional view AKD-H

Technical Data

- T** = Transmissible torque at given T_A
- n_{max}** = Max. rotation speed
- C_{Tdyn}** = Dynamic torsional stiffness
- C_r** = Radial spring stiffness
- C_a** = Axial spring stiffness
- ΔK_a** = Max. permissible axial misalignment
- ΔK_w** = Max. permissible angular misalignment
- ΔK_r** = Max. permissible radial misalignment
- J** = Total moment of inertia
- G_w** = Weight
- D_{G1}** = Thread
- T_{A1}** = Tightened torque of clamping screw D_{G1}

Technical Data

Size	T	n_{max}	C_{Tdyn}	C_r	C_a	ΔK_a	ΔK_w	ΔK_r	J	G _w	D _{G1}	T _{A1}
	ft-lbs	rpm	10 ³ ft-lbs/rad	lbs/inch		inch	Degree	inch	lbs-in ²	lbs	mm	ft-lbs
18	16	12700	4	485	228	0.02	1.5	0.008	0.2	0.4	2 x M5	4
30	27	10200	18	1256	171	0.02	1.5	0.008	0.3	0.6	2 x M6	9
60	55	8600	37	1884	314	0.02	1.5	0.008	1.0	1	2 x M8	22
80	70	6800	55	2284	314	0.02	1.5	0.008	3.1	2	2 x M10	44
150	133	6800	74	3426	485	0.02	1.5	0.008	3.1	2	2 x M10	63
200	177	6300	89	2570	485	0.02	1.5	0.008	5.1	3	2 x M12	74
300	266	5900	207	8565	857	0.02	1.5	0.008	10.9	3	2 x M12	89
500	443	4900	229	5710	485	0.039	1.5	0.008	16.7	5	2 x M14	140
800	590	5000	575	35403	571	0.138	1.5	0.014	59.8	13	2 x M16	184

Transmissible torque T [Nm]

Size	Ø mm Ø inch																				
	8 0.315	9 0.354	10 0.394	11 0.433	12 0.472	14 0.551	15 0.591	18 0.707	20 0.787	24 0.945	25 0.984	30 1.181	35 1.378	40 1.575	45 1.772	50 1.989	55 2.165	60 2.362	64 2.520	70 2.756	75 2.953
18	10	11	13	14	15	16	16	16	16	16	16	---	---	---	---	---	---	---	---	---	---
30	---	---	21	22	24	27	27	27	27	27	27	27	---	---	---	---	---	---	---	---	---
60	---	---	---	---	46	55	55	55	55	55	55	55	55	---	---	---	---	---	---	---	---
80	---	---	---	---	---	70	70	70	70	70	70	70	70	70	---	---	---	---	---	---	---
150	---	---	---	---	---	123	133	133	133	133	133	133	133	133	---	---	---	---	---	---	---
200	---	---	---	---	---	---	---	---	---	177	177	177	177	177	177	---	---	---	---	---	---
300	---	---	---	---	---	---	---	---	---	252	266	266	266	266	266	266	266	266	---	---	---
500	---	---	---	---	---	---	---	---	---	---	---	---	443	443	443	443	443	443	443	---	---
800	---	---	---	---	---	---	---	---	---	---	---	---	---	590	590	590	590	590	590	590	590

Dimensions

- $d_1; d_{2min}$ = Min. bore diameter
 $d_1; d_{2max}$ = Max. bore diameter
B = Bellow outer diameter
C = Pitch circle diameter
 C_1 = Guided length in hub boring d_1
 D_1 = Outer diameter hub
L = Total length
 L_1 = Length of coupling
 L_4 = Length of coupling piece (without conical bushing)



Dimensions

Size	$d_1; d_2$ min-max Without keyway	B	C	C_1	D_1	L	L_1	L_4
30	0.354 - 0.787	2.205	1.220	0.787	2.165	2.047/2.362	1.772/2.087	1.181/1.496
60	0.472 - 0.984	2.598	1.457	0.984	2.520	2.480/2.874	2.165/2.559	1.378/1.811
80	0.591 - 1.378	3.228	2.008	1.181	3.150	3.110/3.583	2.835/3.268	1.929/2.402
150	0.591 - 1.378	3.228	2.008	1.181	3.150	3.110/3.583	2.835/3.307	1.929/2.402
200	0.591/1.382/0.591/1.382 - 1.378/1.654/1.378/1.654	3.543	2.008/2.205/2.008/2.205	1.181	3.543	3.150/3.150/3.661/3.661	2.835/2.835/3.346/3.346	1.969/1.969/2.480/2.480
300	0.591/1.181/0.591/1.181 - 1.654/1.969/1.654/1.969	4.331	2.441/2.953/2.441/2.953	1.299	4.331	3.661/3.661/4.094/4.094	3.150/3.150/3.661/3.661	2.205/2.205/2.638/2.638
500	0.945/1.575/0.945/1.575 - 1.969/2.165/1.969/2.165	4.803	2.953/3.150/2.953/3.150	1.496	4.685	4.016/4.016/4.449/4.449	3.701/3.701/4.134/4.134	2.402/2.402/2.835/2.835
800	1.181/2.366 - 2.362/2.756	6.181	3.622/3.937	2.362	5.512	6.693	5.906	4.331
1400	1.378/2.362 - 2.362/2.756	6.181	3.622/3.937	2.362	5.512	6.693	5.906	4.331
3000	1.969/2.760 - 2.756/3.150	7.835	3.937/4.921	2.362	7.087	7.520	6.732	5.157
5000	2.362/2.760 - 2.756/3.543	9.843	3.937/4.921	2.559	9.055	7.835	7.047	5.472

Transmission of the couplings transmissible torque T can not longer be guaranteed for certain with borings $< d_{min}$. Types with borings $< d_{min}$, however, can be supplied. Moment of inertia and weight (mass) are calculated with reference to the largest bore size.

Characteristics

- Metal bellows made of stainless steel, conical bushings made of steel
- Hubs up to size 500 made of aluminum, sizes 800 – 5000 hubs made of steel
- The shaft tolerance should be within the fit tolerance "g6" or "h7"
- The contact surfaces have to be free from oil and grease
- Optional special design in stainless steel

The torque values shown in the technical data tables can only be safely transmitted if all instructions are followed.

Ordering example: AK

Series Size	Length L	Bore diameter d_1	Bore diameter d_2	Further details*
AK 150	3.110	1.181	1.378	*

* Stainless steel

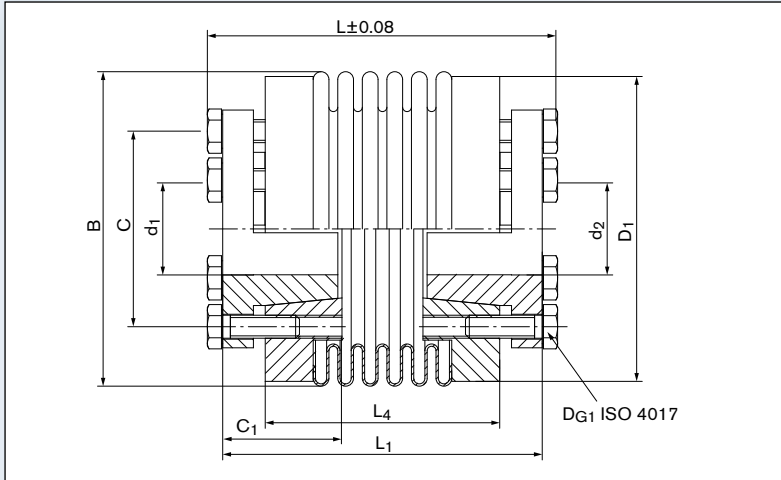

Sectional view AK

Technical Data

- T** = Transmissible torque at given T_A
- n_{max}** = Max. rotation speed
- C_{Tdyn}** = Dynamic torsional stiffness
- C_r** = Radial spring stiffness
- C_a** = Axial spring stiffness
- ΔK_a** = Max. permissible axial misalignment
- ΔK_w** = Max. permissible angular misalignment
- ΔK_r** = Max. permissible radial misalignment
- J** = Total moment of inertia
- Gw** = Weight
- D_{G1}** = Thread
- T_{A1}** = Tightened torque of clamping screw D_{G1}

Technical Data

Size	T	n_{max}	C_{Tdyn}	C_r	C_a	ΔK_a	ΔK_w	ΔK_r	J	Gw	D _{G1}	T _{A1}
	ft-lbs	rpm	10 ³ ft-lbs/rad	lbs/inch		±inch	Degree	inch	lbs-in ²	lbs	mm	ft-lbs
30	27	11000	25.8/18.4	4111/1256	286/171	0.016/0.020	1.0/1.5	0.004/0.008	0.5	0.62	6 x M4	2.2
60	53	9100	55.3/36.9	6281/1884	514/314	0.016/0.020	1.0/1.5	0.004/0.008	0.8	1.10	6 x M6	6.3
80	71	7000	95.9/55.3	6852/2284	457/314	0.016/0.020	1.0/1.5	0.008	2.2	1.90	6 x M6	7.4
150	133	7000	110.6/73.8	11420/3426	857/485	0.016/0.020	1.0/1.5	0.008	2.2	1.90	6 x M6	10.0
200	177	6700	125.4/125.4/88.5/88.5	14275/14275/2570/2570	857/857/485/485	0.016/0.016/0.020/0.020	1.0/1.0/1.5/1.5	0.008	3.0	2.20/2.22/2.20/2.22	6 x M6	10.0/10.3/10.0/10.3
300	266	5200	234.5/368.8/206.5/206.5	35973/35973/8565/8565	1342/1599/857/857	0.016/0.016/0.020/0.020	1.0/1.0/1.5/1.5	0.008	8.0	4.20/4.22/4.20/4.22	6 x M8	13.0/13.3/13.0/13.3
500	443	4600	501.5/501.5/228.6/228.6	50248/50248/5710/5710	571/571/485/485	0.020/0.020/0.039/0.039	1.0/1.0/1.5/1.5	0.008	20.0/19.6/20.0/19.6	5.40	6 x M8	19.0/19.2/19.0/19.2
800	590	3700	561.0/560.6	2912	1085	0.039	1.5	0.008	89.0/89.2	22.00	6 x M16	37.0/36.9
1400	1033	3700	959.0/958.8	4054	1599	0.039	1.5	0.008	89.0/89.2	20.00/20.29	6 x M16	59.0
3000	2213	2800	2065.0/2065.2	46023	5025	0.039	1.5	0.008	297.0/296.7	32.00/32.12	6 x M16	96.0/95.9
5000	3688	2800	3540.0/3540.3	52475	4208	0.039	1.5	0.008	582.0/581.9	54.00/53.57	6 x M16	155.0/154.9

Transmissible torque T [Nm]

Size	Ø mm Ø inch																						
	9 0.354	10 0.394	12 0.472	14 0.551	15 0.591	18 0.707	20 0.787	24 0.945	28 1.102	32 1.260	38 1.496	44 1.732	48 1.890	50 1.989	58 2.283	60 2.362	65 2.560	70 2.756	75 2.953	80 3.150	85 3.346	90 3.543	
30	27	27	27	27	27	27	27	---	---	---	---	---	---	---	---	---	---	---	---	---	---	---	---
60	---	---	53	53	53	53	53	53	---	---	---	---	---	---	---	---	---	---	---	---	---	---	---
80	---	---	---	---	71	71	71	71	71	71	---	---	---	---	---	---	---	---	---	---	---	---	---
150	---	---	---	---	133	133	133	133	133	133	---	---	---	---	---	---	---	---	---	---	---	---	---
200	---	---	---	---	177	177	177	177	177	177	---	---	---	---	---	---	---	---	---	---	---	---	---
300	---	---	---	---	214	258	266	266	266	266	266	266	266	---	---	---	---	---	---	---	---	---	---
500	---	---	---	---	---	---	---	443	443	443	443	443	443	443	---	---	---	---	---	---	---	---	---
800	---	---	---	---	---	---	---	---	590	590	590	590	590	590	590	590	590	590	---	---	---	---	---
1400	---	---	---	---	---	---	---	---	1033	1033	1033	1033	1033	1033	1033	1033	1033	1033	1033	---	---	---	---
3000	---	---	---	---	---	---	---	---	---	---	---	---	2213	2213	2213	2213	2213	2213	2213	2213	2213	---	---
5000	---	---	---	---	---	---	---	---	---	---	---	---	---	---	3688/---	3688	3688	3688	3688	3688	3688	3688	3688

Dimensions

- d₁; d₂** = Inner diameter
B = Bellow outer diameter
C = Pitch circle diameter
D₁ = Outer diameter hub
L = Total length
M = Max. depth of thread



Dimensions

Size	d ₁ ; d ₂	B	C	D ₁	L	M
		inch		inch	inch	mm
18	0.866	1.811	1.220	1.811	1.417/1.732	6
30	1.102	2.205	1.457	2.165	1.181/1.496	7
60	1.496	2.598	1.811	2.520	1.614/2.008	10
80	1.969	3.228	2.441	3.150	2.047/2.441	13
150	1.969	3.228	2.441	3.150	2.047/2.441	13
200	1.969	3.543	2.441	3.543	2.008/2.480	13
300	1.969	4.331	3.150	4.291	2.165/2.598	13
500	2.756	4.803	3.701	4.685	2.402/2.835	16
800	3.346	6.181	4.331	5.984	5.118	18
1400	3.346	6.181	4.331	5.984	5.118	18
3000	3.937	7.835	5.512	7.087	5.118	25
5000	5.709	9.843	7.480	9.055	5.630	25

Characteristics

- Metal bellows made of stainless steel
- Hubs up to size 500 made of aluminum, sizes 800 and larger hubs made of steel
- The contact surfaces have to be free from oil and grease
- Optional special design in stainless steel

The torque values shown in the technical data tables can only be safely transmitted if all instructions are followed.

Ordering example: CKN

Series Size	Length L	Further details*
CKN 150	2.047	*

* Stainless steel

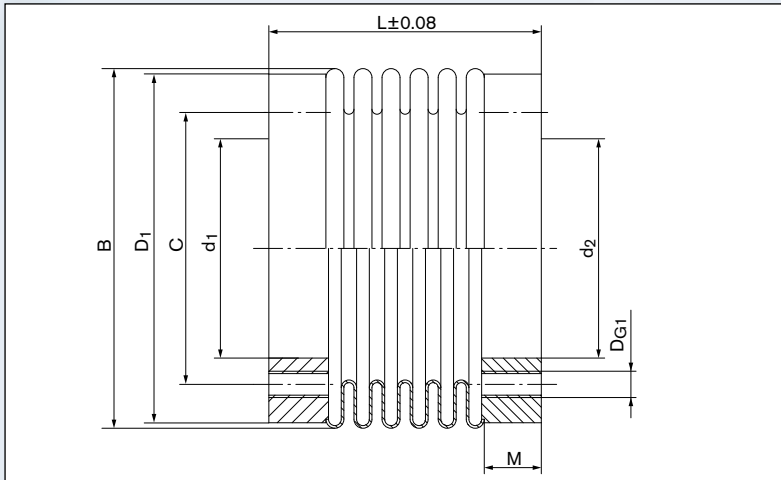

Sectional view CKN

Technical Data

- T** = Transmissible torque at given T_A
- n_{max}** = Max. rotation speed
- C_{Tdyn}** = Dynamic torsional stiffness
- C_r** = Radial spring stiffness
- C_a** = Axial spring stiffness
- ΔK_a** = Max. permissible axial misalignment
- ΔK_w** = Max. permissible angular misalignment
- ΔK_r** = Max. permissible radial misalignment
- J** = Total moment of inertia
- Gw** = Weight
- D_{G1}** = Thread
- T_{A1}** = Tightened torque of clamping screw D_{G1}

Technical Data

Size	T	n_{max}	C_{Tdyn}	C_r	C_a	ΔK_a	ΔK_w	ΔK_r	J	Gw	D_{G1}	T_{A1}
	ft-lbs	rpm	10^3 ft-lbs/rad	lbs/inch	lbs/inch	±inch	Degree	inch	lbs-in ²	lbs	mm	ft-lbs
18	16	13900	5.9/4.4	1142.0/485.4	285.5/228.4	0.020	1.5	0.008	0.2	0.14	6 x M5	4.4
30	27	11000	25.8/18.4	4111.2/1256.2	285.5/171.3	0.016/0.020	1.0/1.5	0.004/0.008	0.3	0.26	6 x M5	4.4
60	55	9000	55.3/36.9	6281.0/1884.3	513.9/314.1	0.016/0.020	1.0/1.5	0.004/0.008	0.5	0.42	6 x M6	7.4
80	71	7100	95.9/55.3	6852.0/2284.0	456.8/314.1	0.016/0.020	1.0/1.5	0.008	1.5	0.78	6 x M6	7.4
150	133	7100	110.6/73.8	11420.0/3426.0	856.5/485.4	0.016/0.020	1.0/1.5	0.008	1.5	0.78	6 x M6	11.0
200	177	6600	125.4/88.5	14275.0/2569.5	856.5/485.4	0.016/0.020	1.0/1.5	0.008	2.7	1.05	6 x M6	13.0
300	266	5200	368.8/206.5	35973.0/8565.0	1598.8/856.5	0.016/0.020	1.0/1.5	0.008	5.8	1.30	6 x M8	18.0
500	443	4600	501.5/228.6	50248.0/5710.0	571.0/485.4	0.020/0.039	1.0/1.5	0.008	7.9	1.93	6 x M8	27.0
800	708	3700	560.6	2912.1	1084.9	0.039	1.5	0.008	37.6	8.20	6 x M16	155.0
1400	1239	3700	958.8	4054.1	1598.8	0.039	1.5	0.008	37.6	8.20	6 x M16	155.0
3000	2213	3700	2065.2	46022.6	5024.8	0.039	1.5	0.008	160.6	17.20	6 x M20	269.0
5000	3688	3000	3540.3	52474.9	4208.3	0.039	1.5	0.008	406.6	26.00	8 x M20	269.0

Screw quality should be selected according to the tightening torque.
The contact surfaces have to be dry and free from oil and grease.

Technical Information · Metal Bellows Couplings

Design/Sample calculation

Design/Product information

Backlash-free, torsionally stiff metal bellows couplings are ready to install when delivered. The metal bellows are made of stainless steel, all other parts are made of aluminum or steel. The shaft tolerance should be within the fit tolerance "g6" or "h7". The power transmission between the coupling hub and the shaft is generated by compression and friction between the contact surfaces. Special attention must be paid to the tightening torque of the retaining screws as well as the perfect condition of the surfaces. The contact surfaces must be free of oil and grease and have a surface finish of R_{tmax} . 0.00063 in for the shaft. Versions with keyway are available. The torques indicated can be guaranteed if you follow all instructions.

Dimensioning in accordance with the torque

Metal bellows couplings are generally mostly selected according to the transmissible torque. In all cases the torque of the selected coupling size must be higher than the regular transmitted torque. This generally applies to the use of servo motors, whose acceleration torque in both positive and negative directions exceeds the nominal torque. For the use of metal bellows couplings which are fitted in controlled, high dynamic drives, the following dimensioning values (K) have proven to be reliable in practice:

K = 1.5 for evenly shaped movements

K = 2 for unevenly shaped movements

K = 2.5 – 4 for jerky movements

For servo drives within tool making machines, the values for

K= 1.5 – 2 should be used.

We would be pleased to design your metal bellows coupling for you. Feel free to use our experience and know-how for your success. Give us a call!

$$T \geq K \cdot T_{AS} \cdot \frac{J_{mach}}{J_{eng} + J_{mach}} \text{ [ft-lbs]}$$

Example

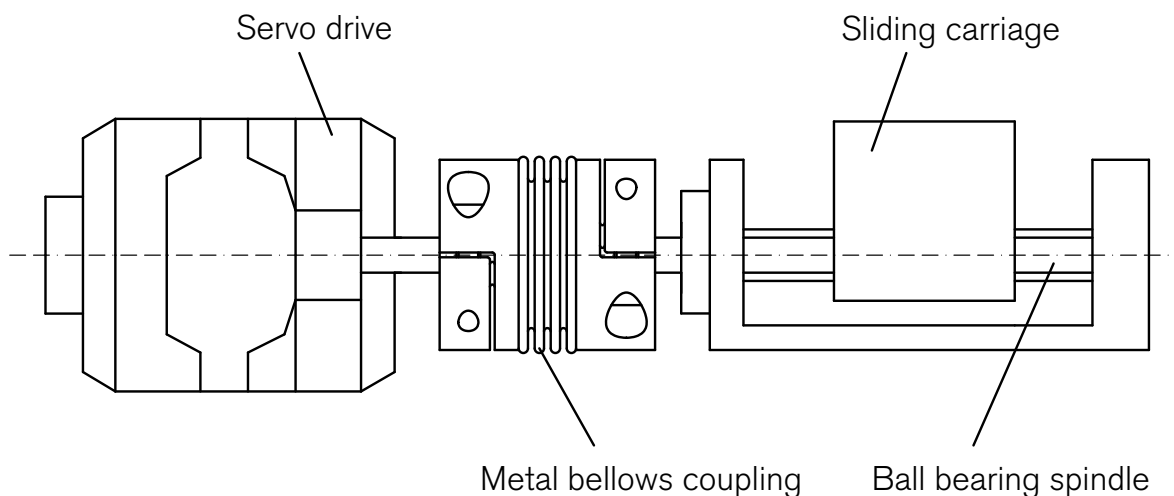

Technical Information · Metal Bellows Couplings

Design in consideration of dynamic torsional stiffness

Although metal bellows couplings are backlash-free and torsion-rigid, it should not be ignored that they link two rotating masses. In adverse cases the couplings can act like a torsion spring with high stiffness. The regulating oscillation of the drives and the harmonic oscillation in the armature current of the motor therefore must never be within the range of the mechanical resonance frequency. In practice the resonance frequency “ f_{res} ” must be twice as high as the excitation frequency of the drive.

The dynamic torsional stiffness C_{Tdyn} was selected so that it would not be within the range of parasitic oscillation of most applications. Various levels of torsional stiffness are available as standard versions.

We would be pleased to design your metal bellows couplings for you. Feel free to use our experience and know-how for your success. Give us a call!

Calculation for the application of a metal bellows coupling in a machine tool drive

Drive related data for servo motor/FT 5104: Peak torque $T_{AS} = 118$ ft-lbs
Moment of inertia
 $J_{eng} = 62.543$ lbs-in²

The low moment of inertia for the metal bellows coupling is disregarded. $K =$ Load factor, impulse factor selected for this drive $K = 2$

Output data for machine tool: Moment of inertia of ball screw and slide: $J_{mach} = 58.1$ lbs-in²

$$f_{res} = \frac{1}{2\pi} \sqrt{C_{Tdyn} \cdot \frac{J_{eng} + J_{mach}}{J_{eng} \cdot J_{mach}}} \text{ [Hz]}$$

Design according to torque:

Coupling selection:
AKD 200, $T = 177$ ft-lbs, $C_{Tdyn} = 89 \times 10^3$ ft-lbs/rad

The metal bellows coupling is dimensioned sufficient, since 177 ft-lbs $>$ 113.6 ft-lbs

$$T \geq K \cdot T_{AS} \cdot \frac{J_{mach}}{J_{eng} + J_{mach}} = 118 \text{ [ft-lbs]} \cdot \frac{58.1 \text{ [lbs-in}^2\text{]}}{62.543 + 58.1 \text{ [lbs-in}^2\text{]}} = 113.6 \text{ [ft-lbs]}$$

Design according the resonance frequency:

The arithmetic calculation is clearly higher than the expected resonance frequency. Usually for the most established nc-machine tools this value is between 150 to 350 Hz.

$$f_{res} = \frac{1}{2\pi} \cdot \sqrt{C_{Tdyn} \cdot \frac{J_{eng} + J_{mach}}{J_{eng} \cdot J_{mach}}} = \frac{1}{2\pi} \cdot \sqrt{1062088.8 \frac{\text{[in-lbs]}}{\text{[rad]}} \cdot 386.2 \frac{\text{[in]}}{\text{[s}^2\text{]}} \cdot \frac{(62.543 + 58.1) \text{ [lbs-in}^2\text{]}}{62.543 \text{ [lbs-in}^2\text{]} \cdot 51.1 \text{ [lbs-in}^2\text{]}}} = 587 \text{ [Hz]}$$

Servo-Insert Couplings Basics

Backlash-free Servo-Insert Couplings

Backlash-free Servo-Insert Couplings are used in mechanical engineering, where shock absorption is requested and pluggable coupling solutions are applied.

Special Features

- Backlash-free
- Pluggable
- Vibration damping
- Torques from 0.22 - 1416 ft-lbs
- Compensation of radial, axial and angular misalignment
- Electrically isolating

Common Applications

- Encoder
- Precision drives
- Feed drives
- Grinding and milling spindles
- Machine tools
- Packing machines
- Robotics
- Transfer lines
- Multi-spindle heads
- Wood processing equipment
- Textile machinery
- Conveying equipment
- Linear motion
- Measuring equipment and control technology
- Test rigs

Hoist

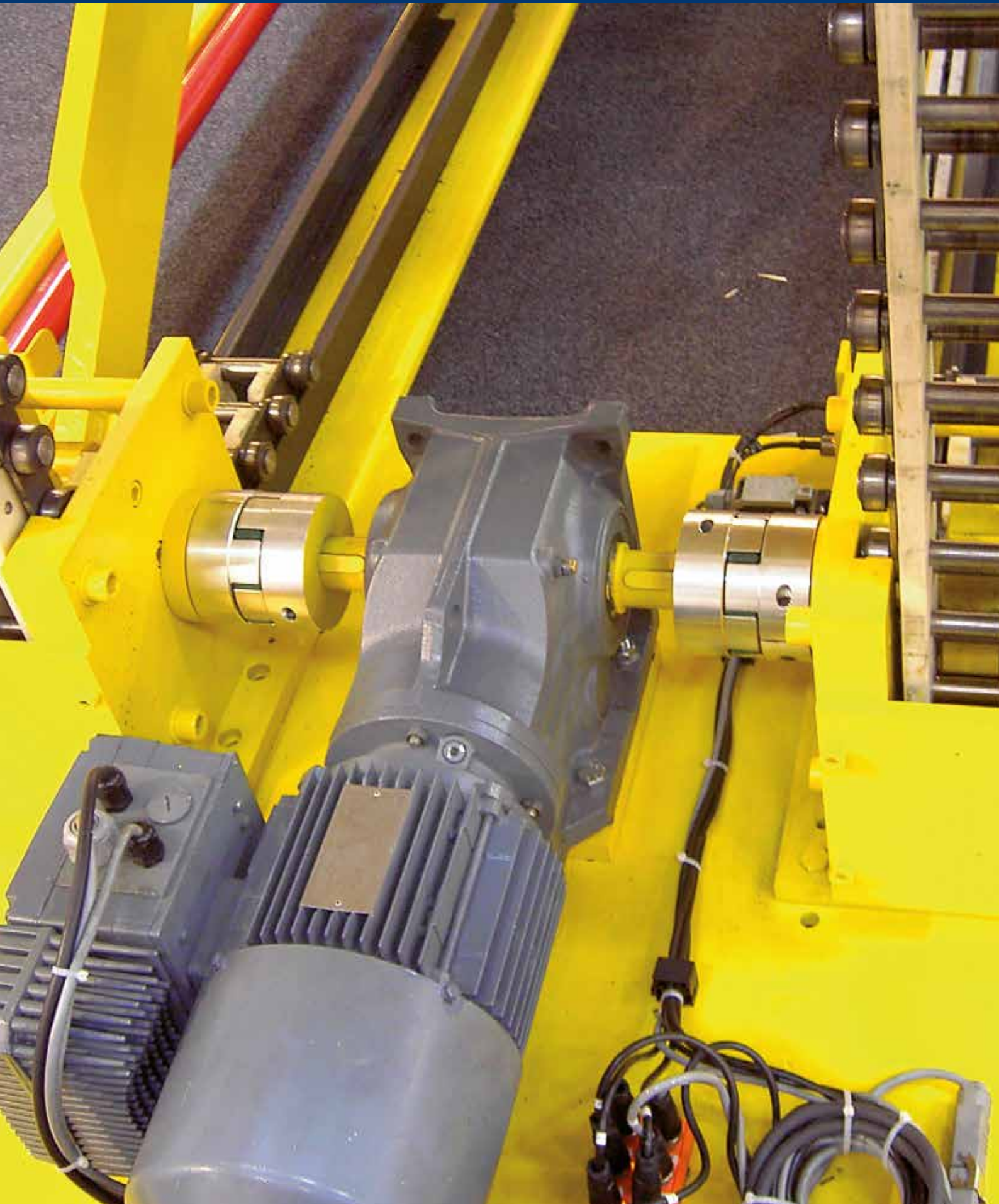

Automation



Overview Servo-Insert Couplings



GERWAH®
GWE 5102

Miniature servo-insert coupling with set screw hubs

Page 40



GERWAH®
GWE 5103

Miniature servo-insert coupling with clamping hubs, short length and single slit

Page 42

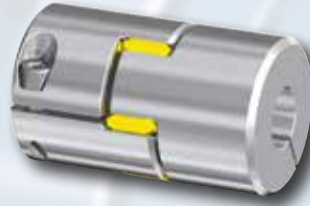

GERWAH®
GWE 5103.1

Miniature servo-insert coupling with clamping hubs and single slit

Page 44



GERWAH®
GWE 5107

Servo-insert coupling with clamping hubs and expanding clamps

Page 46



GERWAH®
GWE 5104

Servo-insert coupling with clamping hubs and dual slits

Page 48



GERWAH®
GWE 5106

Servo-insert coupling with clamping hubs in split hub design

Page 50



GERWAH®
GWE 5112

Servo-insert coupling with outer cone

Page 52

CAD data available: www.ringfeder.com

Dimensions

- $d_1; d_{2min}$ = Min. bore diameter
 $d_1; d_{2max}$ = Max. bore diameter
 $d_{1k}; d_{2kmin}$ = Min. bore diameter with keyway acc. to DIN 6885-1
 $d_{1k}; d_{2kmax}$ = Max. bore diameter with keyway acc. to DIN 6885-1
 C_1 = Guided length in hub boring d_1
 D_1 = Outer diameter hub
 H_3 = Length of damping part
 l = Distance between center screw hole and hub end
 L = Total length



Dimensions

Technical Data

Size	$d_1; d_2$ min-max Without keyway	$d_{1k}; d_{2k}$ min-max With keyway	C_1	D_1	H_3	l	L	T	H_{es}	n_{max}	J	Gw	D_{G1}	T_{A1}
	inch	inch												
5	0.079 - 0.197	--- ---	0.197	0.394	0.197	0.098	0.591	0.37	92 SH A	47500	0.12	0.01	1 x M3	1
7	0.118 - 0.315	0.236 - 0.315	0.276	0.551	0.315	0.138	0.866	0.89	92 SH A	34000	0.67	0.02	1 x M3	1
9	0.118 - 0.472	0.236 - 0.394	0.394	0.787	0.394	0.197	1.181	2.2	92 SH A	24000	3.7	0.04	2 x M4	2.2
12	0.157 - 0.472	0.236 - 0.472	0.433	0.984	0.472	0.197	1.339	3.7	92 SH A	19000	9.7	0.07	2 x M4	3.7
14	0.157 - 0.63	0.236 - 0.63	0.433	1.181	0.512	0.197	1.378	6	92 SH A	16000	19	0.09	2 x M6	4.5
19	0.236 - 0.945	0.236 - 0.945	0.984	1.575	0.63	0.394	2.598	7	92 SH A	12000	123	0.3	2 x M6	4.5
24	0.315 - 1.378	0.315 - 1.378	1.181	2.165	0.709	0.394	3.071	26	92 SH A	8500	554	0.62	2 x M6	4.5
28	--- ---	0.394 - 1.496	1.378	2.559	0.787	0.591	3.543	70	92 SH A	7300	1100	1	2 x M6	4.5
38	--- ---	0.472 - 1.89	1.772	3.15	0.945	0.591	4.488	140	92 SH A	5900	3260	1.93	2 x M6	4.5

Transmission of the couplings transmissible torque T can not longer be guaranteed for certain with borings $< d_{min}$. Types with borings $< d_{min}$, however, can be supplied. Moment of inertia and weight (mass) are calculated with reference to the largest bore size.

Ordering example: GWE 5102

Series Size	Bore diameter d_1	Bore diameter d_2	Further details*
GWE 5102-14	0.393	0.551	*

* Keyway

GERWAH® GWE 5102

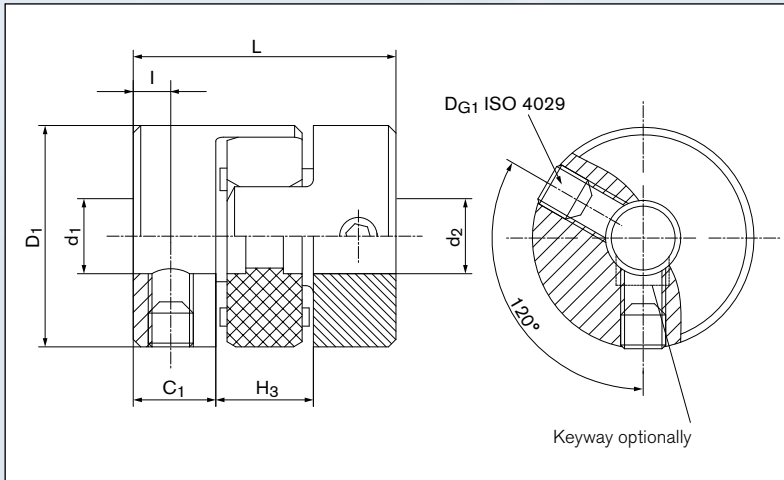

Sectional view GWE 5102

Technical Data

- T** = Transmissible torque at given T_A
- H_{es}** = Hardness of the elastomeric spider
- n_{max}** = Max. rotation speed
- J** = Total moment of inertia
- G_w** = Weight
- D_{G1}** = Thread
- T_{A1}** = Tightened torque of clamping screw D_{G1}

Transmissible torque T [Nm]

Size	Ø mm Ø inch															
	3 0.118	4 0.157	5 0.197	6 0.236	7 0.276	8 0.315	9 0.354	10 0.394	12 0.472	14 0.551	16 0.630	18 0.707	20 0.787	22 0.866	24 0.945	28 1.102
5	0,02	0,02	0,02	---	---	---	---	---	---	---	---	---	---	---	---	---
7	0.89	0.89	0.89	0.89	0.89	0.89	---	---	---	---	---	---	---	---	---	---
9	2.2	2.2	2.2	2.2	2.2	2.2	2.2	2.2	2.2	---	---	---	---	---	---	---
12	---	3.7	3.7	3.7	3.7	3.7	3.7	3.7	3.7	---	---	---	---	---	---	---
14	---	6	6	6	6	6	6	6	6	6	6	---	---	---	---	---
19	---	---	---	7	7	7	7	7	7	7	7	7	7	7	7	---
24	---	---	---	---	---	15	16	18	21	25	26	26	26	26	26	26
28	---	---	---	---	---	---	---	70	70	70	70	70	70	70	70	70
38	---	---	---	---	---	---	---	---	140	140	140	140	140	140	140	140

Characteristics

- Hubs made of aluminum
- Standard elastomeric spider with 92 SH A (yellow spider), optional with through bore hole see page 54/55
- The shaft tolerance should be within the fit tolerance "g6" or "h7"
- The contact surfaces have to be free from oil and grease

The torque values shown in the technical data tables can only be safely transmitted if all instructions are followed.

Dimensions

- $d_1; d_{2min}$ = Min. bore diameter
 $d_1; d_{2max}$ = Max. bore diameter
 $d_{1k}; d_{2kmin}$ = Min. bore diameter with keyway acc. to DIN 6885-1
 $d_{1k}; d_{2kmax}$ = Max. bore diameter with keyway acc. to DIN 6885-1
 C_1 = Guided length in hub boring d_1
 D_1 = Outer diameter hub
 H = Clearance diameter
 H_3 = Length of damping part
 I = Distance between center screw hole and hub end
 K = Distance shaft axis - clamping screw axis
 L = Total length



Dimensions

Technical Data

Size	$d_1; d_2$ min-max	$d_{1k}; d_{2k}$ min-max														
	Without keyway	With keyway	C_1	D_1	H	H_3	I	K	L	T	H_{es}	n_{max}	J	G_w	D_{G1}	T_{A1}
	inch	inch	inch	inch	inch	inch	inch	inch	inch	ft-lbs		rpm	lbs-in ²	lbs	mm	ft-lbs
7	0.118 - 0.276	0.236 - 0.276	0.236	0.551	0.65	0.315	0.118	0.197	0.787	0.89	92 SH A	27000	0.0003	0.01	1 x M2	0.26
9	0.157 - 0.433	0.236 - 0.433	0.315	0.768	0.906	0.394	0.157	0.295	1.024	2.2	92 SH A	19000	0.0007	0.04	1 x M2.5	0.55
12	0.157 - 0.472	0.236 - 0.472	0.276	0.984	1.024	0.472	0.138	0.335	1.024	3.7	92 SH A	15000	0.008	0.05	1 x M3	1.1
14	0.197 - 0.591	0.236 - 0.591	0.374	1.161	1.299	0.512	0.197	0.413	1.26	9	98 SH A	13000	0.021	0.11	1 x M4	3.7
19	0.315 - 0.866	0.315 - 0.866	0.669	1.555	1.693	0.63	0.236	0.591	1.969	13	98 SH A	10000	0.099	0.26	1 x M5	7.5
24	0.394 - 1.22	0.394 - 1.22	0.787	2.146	2.205	0.709	0.394	0.787	2.283	44	98 SH A	7000	0.413	0.62	1 x M6	13
28	0.551 - 1.378	0.551 - 1.378	0.846	2.539	2.638	0.748	0.433	0.925	2.441	118	98 SH A	6000	0.806	0.78	1 x M8	26
38	0.591 - 1.811	0.591 - 1.811	1.22	3.13	3.465	0.906	0.512	1.181	3.346	240	98 SH A	5000	2.723	1.9	1 x M10	62
42	0.787 - 2.205	0.787 - 2.205	1.496	3.72	3.74	1.024	0.551	1.378	4.016	332	98 SH A	4000	6.079	3.3	1 x M10	62

Transmission of the couplings transmissible torque T can no longer be guaranteed for certain with borings $< d_{min}$. Types with borings $< d_{min}$, however, can be supplied. Moment of inertia and weight (mass) are calculated with reference to the largest bore size.

Ordering example: GWE 5103

Series Size	Bore diameter d_1	Bore diameter d_2	Further details*
GWE 5103-42	0.787	1.732	*

* Keyway or stainless steel

GERWAH® GWE 5103

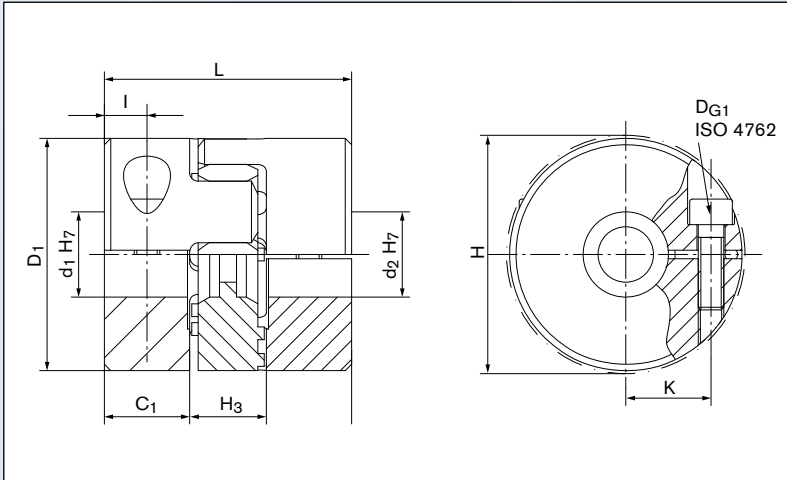

Sectional view GWE 5103

Technical Data

- T** = Transmissible torque at given T_A
- H_{es}** = Hardness of the elastomeric spider
- n_{max}** = Max. rotation speed
- J** = Total moment of inertia
- G_w** = Weight
- D_{G1}** = Thread
- T_{A1}** = Tightened torque of clamping screw D_{G1}

Transmissible torque T [Nm]

Size	Ø mm Ø inch																				
	3	4	5	6	8	10	12	14	15	18	20	25	26	28	30	35	40	45	50	55	56
7	0.52	0.66	0.81	0.89	---	---	---	---	---	---	---	---	---	---	---	---	---	---	---	---	---
9	---	1.3	1.5	1.8	2.2	2.2	---	---	---	---	---	---	---	---	---	---	---	---	---	---	---
12	---	2.1	2.7	3.1	3.7	3.7	3.7	---	---	---	---	---	---	---	---	---	---	---	---	---	---
14	---	---	7	8	9	9	9	9	9	---	---	---	---	---	---	---	---	---	---	---	---
19	---	---	---	---	13	13	13	13	13	13	13	---	---	---	---	---	---	---	---	---	---
24	---	---	---	---	---	32	38	44	44	44	44	44	44	44	44	---	---	---	---	---	---
28	---	---	---	---	---	---	---	68	72	85	93	113	117	118	118	118	---	---	---	---	---
38	---	---	---	---	---	---	---	---	141	267	283	223	230	240	240	240	240	240	---	---	---
42	---	---	---	---	---	---	---	---	---	---	184	225	233	249	264	302	332	332	332	332	332

Characteristics

- Hubs made of aluminum
- Elastomeric spider sizes 7 and 9 with 92 SH A (yellow spider)
- Elastomeric spider sizes 14 and 42 with 98 SH A (red spider), optional with through bore hole see page 54/55
- The shaft tolerance should be within the fit tolerance "g6" or "h7"
- The contact surfaces have to be free from oil and grease

The torque values shown in the technical data tables can only be safely transmitted if all instructions are followed.

Dimensions

- $d_1; d_{2min}$ = Min. bore diameter
 $d_1; d_{2max}$ = Max. bore diameter
 $d_{1k}; d_{2kmin}$ = Min. bore diameter with keyway acc. to DIN 6885-1
 $d_{1k}; d_{2kmax}$ = Max. bore diameter with keyway acc. to DIN 6885-1
 C_1 = Guided length in hub boring d_1
 D_1 = Outer diameter hub
 H = Clearance diameter
 H_3 = Length of damping part
 I = Distance between center screw hole and hub end
 K = Distance shaft axis - clamping screw axis
 L = Total length



Dimensions

Technical Data

Size	$d_1; d_2$ min-max Without keyway	$d_{1k}; d_{2k}$ min-max With keyway	C_1	D_1	H	H_3	I	K	L	T	H_{es}	n_{max}	J	G_w	D_{G1}	T_{A1}
	inch	inch														
5	0.079 - 0.157	---	0.197	0.394	0.453	0.197	0.098	0.126	0.591	0.37	92 SH A	38000	0.12	0.01	1 x M1.6	0.19
7	0.118 - 0.276	0.236 - 0.276	0.276	0.551	0.65	0.315	0.138	0.197	0.866	0.89	92 SH A	27000	0.67	0.02	1 x M2	0.26
9	0.118 - 0.433	0.236 - 0.433	0.394	0.787	0.925	0.394	0.197	0.287	1.181	2.2	92 SH A	19000	3.7	0.03	1 x M2.5	0.55

Transmission of the couplings transmissible torque T can no longer be guaranteed for certain with borings $< d_{min}$. Types with borings $< d_{min}$, however, can be supplied. Moment of inertia and weight (mass) are calculated with reference to the largest bore size.

Ordering example: GWE 5103.1

Series Size	Bore diameter d_1	Bore diameter d_2	Further details*
GWE 5103.1-9	0.157	0.394	*

* Keyway

GERWAH® GWE 5103.1

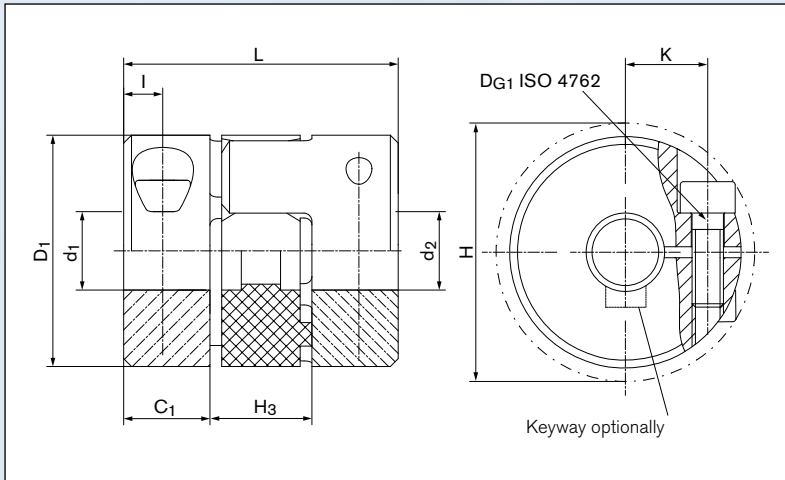

Sectional view GWE 5103.1

Technical Data

- T** = Transmissible torque at given T_A
- H_{es}** = Hardness of the elastomeric spider
- n_{max}** = Max. rotation speed
- J** = Total moment of inertia
- G_w** = Weight
- D_{G1}** = Thread
- T_{A1}** = Tightened torque of clamping screw D_{G1}

Transmissible torque T [Nm]

Size	Ø mm Ø inch										
	2 0.079	3 0.118	4 0.157	5 0.197	6 0.236	7 0.276	8 0.315	9 0.354	10 0.394	11 0.433	
5	0.37	0.37	0.37	---	---	---	---	---	---	---	
7	---	0.59	0.81	0.89	0.89	0.89	---	---	---	---	
9	---	1.1	1.5	1.8	2.1	2.2	2.2	2.2	2.2	2.2	

Characteristics

- Hubs made of aluminum
- Standard elastomeric spider with 92 SH A (yellow spider), optional with through bore hole see page 54/55
- The shaft tolerance should be within the fit tolerance "g6" or "h7"
- The contact surfaces have to be free from oil and grease

The torque values shown in the technical data tables can only be safely transmitted if all instructions are followed.

Dimensions

- d_{1min} = Min. bore diameter
 d_{1max} = Max. bore diameter
 d_{1kmin} = Min. bore diameter with keyway acc. to DIN 6885-1
 d_{1kmax} = Max. bore diameter with keyway acc. to DIN 6885-1
 C_1 = Guided length in hub boring d_1
 D_1 = Outer diameter hub
 D_{4min} = Min. outer diameter of the cone hub
 D_{4max} = Max. outer diameter of the cone hub
 H = Clearance diameter
 H_3 = Length of damping part
 l = Distance between center screw hole and hub end
 K = Distance shaft axis - clamping screw axis
 L = Total length
 L_5 = Expanding mandrel length



Dimensions

Technical Data

Size	d_1 min-max Without keyway	d_{1k} min-max With keyway	C_1	D_1	D_4		H	H_3	l	K	L	L_5	T	H_{es}	n_{max}	J	G_w	D_{G1}	T_{A1}	D_{G2}	T_{A2}
	inch	inch			min-max	inch															
9	0.157 - 0.433	0.236 - 0.433	0.315	0.768	0.394 - 0.591	0.886	0.394	0.157	0.287	1.339	0.472	2.21	92 SH A	19000	0.007	0.09	1 x M2.5	0.55	1 x M4	3	
12	0.157 - 0.472	0.236 - 0.472	0.276	0.984	0.394 - 0.591	1.024	0.472	0.138	0.335	1.496	0.472	3.69	92 SH A	15000	0.016	0.14	1 x M3	1.1	1 x M4	3	
14	0.197 - 0.591	0.236 - 0.591	0.374	1.161	0.512 - 0.984	1.299	0.512	0.197	0.413	1.89	0.787	9.22	98 SH A	13000	0.038	0.24	1 x M4	3.7	1 x M5	6.7	
19	0.315 - 0.866	0.315 - 0.866	0.669	1.555	0.551 - 1.181	1.693	0.630	0.236	0.591	2.559	0.984	12.54	98 SH A	10000	0.15	0.57	1 x M5	7.5	1 x M6	9	
24	0.394 - 1.220	0.394 - 1.220	0.787	2.146	0.906 - 1.417	2.205	0.709	0.394	0.787	2.874	1.063	44.25	98 SH A	7000	0.56	1.1	1 x M6	13	1 x M8	24	
28	0.551 - 1.378	0.551 - 1.378	0.846	2.539	1.024 - 1.654	2.638	0.748	0.433	0.925	3.268	1.26	118.01	98 SH A	6000	1.3	1.8	1 x M8	32	1 x M10	45	

Transmission of the couplings transmissible torque T can no longer be guaranteed for certain with borings $< d_{min}$. Types with borings $< d_{min}$, however, can be supplied. Moment of inertia and weight (mass) are calculated with reference to the largest bore size.

Ordering example: GWE 5107

Series Size	Bore diameter d_1	Outer diameter of the cone hub D_4	Further details*
GWE 5107-24	0.984	1.102	*

* Keyway

GERWAH® GWE 5107

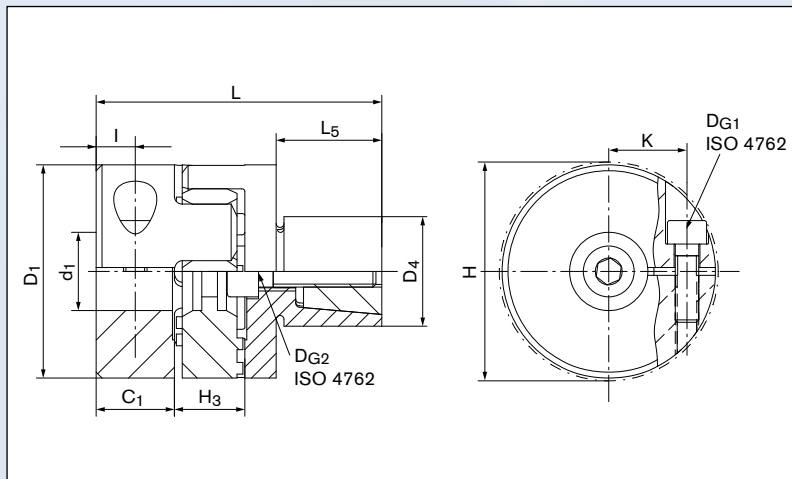

Sectional view GWE 5107

Technical Data

- T** = Transmissible torque at given T_A
- H_{es}** = Hardness of the elastomeric spider
- n_{max}** = Max. rotation speed
- J** = Total moment of inertia
- G_w** = Weight
- D_{G1}** = Thread
- D_{G2}** = Thread
- T_{A1}** = Tightened torque of clamping screw D_{G1}
- T_{A2}** = Tightened torque of clamping screw D_{G2}

Transmissible torque T [Nm]

Size	Ø mm Ø inch															
	4 0.157	5 0.197	6 0.236	8 0.315	10 0.394	12 0.472	14 0.551	15 0.591	18 0.707	20 0.787	25 0.984	26 1.023	28 1.102	30 1.181	35 1.378	
9	1.3	1.5	1.8	2.2	2.2	---	---	---	---	---	---	---	---	---	---	
12	2.1	2.7	3.3	4	4	4	---	---	---	---	---	---	---	---	---	
14	---	7	8	9	9	9	9	10	---	---	---	---	---	---	---	
19	---	---	---	13	13	13	13	13	13	13	---	---	---	---	---	
24	---	---	---	---	32	38	44	44	44	44	44	44	44	44	---	
28	---	---	---	---	---	---	83	89	104	114	118	118	118	118	118	

Characteristics

- Hubs made of aluminum
- Expanding mandrel and inner cone made of steel
- Elastomeric spider sizes 7 and 9 with 92 SH A (yellow spider), optional with through bore hole see page 54/55
- Elastomeric spider sizes 14 and 42 with 98 SH A (red spider), optional with through bore hole see page 54/55
- The shaft tolerance should be within the fit tolerance "g6" or "h7"
- For the bore tolerances we recommend fit tolerance H7
- The contact surfaces have to be free from oil and grease

The torque values shown in the technical data tables can only be safely transmitted if all instructions are followed.

Dimensions

- $d_1; d_{2min}$ = Min. bore diameter
 $d_1; d_{2max}$ = Max. bore diameter
 $d_{1k}; d_{2kmin}$ = Min. bore diameter with keyway acc. to DIN 6885-1
 $d_{1k}; d_{2kmax}$ = Max. bore diameter with keyway acc. to DIN 6885-1
 C_1 = Guided length in hub boring d_1
 D_1 = Outer diameter hub
 D_3 = Outer diameter hub
 H = Clearance diameter
 H_3 = Length of damping part
 I = Distance between center screw hole and hub end
 K = Distance shaft axis - clamping screw axis
 L = Total length
 L_3 = Section length of hub



Dimensions

Technical Data

Size	$d_1; d_2$ min-max	$d_{1k}; d_{2k}$ min-max																
	Without keyway	With keyway	C_1	D_1	D_3	H	H_3	I	K	L	L_3	T	H_{es}	n_{max}	J	G_w	D_{G1}	T_{A1}
	inch	inch	inch	inch	inch	inch	inch	inch	inch	inch	inch	ft-lbs		rpm	lbs-in ²	lbs	mm	ft-lbs
14	0.197 - 0.63	0.197 - 0.63	0.433	1.181	---	1.268	0.512	0.197	0.433	1.378	---	9	98 SH A	13000	0.021	0.09	1 x M3	1.5
19	0.236 - 0.787	0.236 - 0.787	0.984	1.575	---	1.811	0.63	0.472	0.571	2.598	---	13	98 SH A	10000	0.12	0.35	1 x M6	8
24	0.394 - 1.26	0.394 - 1.26	1.181	2.165	---	2.244	0.709	0.413	0.787	3.071	---	44	98 SH A	7000	0.51	0.7	1 x M6	11
28	0.394 - 1.496	0.394 - 1.496	1.378	2.559	---	2.795	0.787	0.453	0.965	3.543	---	118	98 SH A	6000	1.1	1.1	1 x M8	24
38	0.472 - 1.89	0.472 - 1.89	1.772	3.15	---	3.268	0.945	0.61	1.181	4.488	---	240	98 SH A	5000	3.3	2.1	1 x M8	28
42	0.551 - 2.126	0.551 - 2.126	1.969	3.74	3.346	3.74	1.024	0.709	1.28	4.961	1.102	332	98 SH A	4000	17	8.4	1 x M10	62
48	0.591 - 2.362	0.591 - 2.362	2.205	4.134	3.74	4.173	1.102	0.827	1.457	5.512	1.26	387	98 SH A	3600	28	11	1 x M12	107
55	1.378 - 2.913	1.378 - 2.913	2.559	4.724	---	4.724	1.181	1.024	1.772	6.299	---	505	98 SH A	3150	65	22	1 x M12	107
65	1.378 - 3.15	1.378 - 3.15	2.953	5.315	---	5.315	1.378	1.102	1.969	7.283	---	693	95 SH A	2800	105	30	1 x M12	107
75	1.181 - 3.74	1.181 - 3.74	3.346	6.299	---	6.299	1.575	1.417	2.362	8.268	---	1416	95 SH A	2350	228	47	1 x M16	218

Transmission of the couplings transmissible torque T can no longer be guaranteed for certain with borings $< d_{min}$. Types with borings $< d_{min}$, however, can be supplied. Moment of inertia and weight (mass) are calculated with reference to the largest bore size.

Ordering example: GWE 5104

Series Size	Bore diameter d_1	Bore diameter d_2	Further details*
GWE 5104-42	0.787	0.984	*

* Keyway

GERWAH® GWE 5104

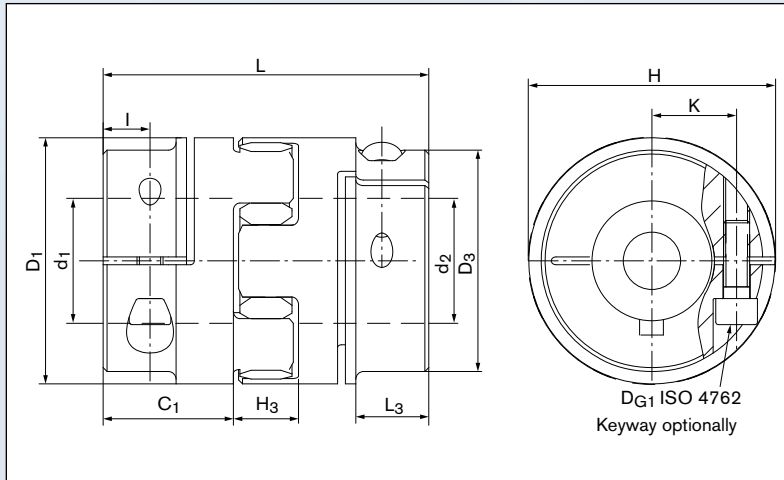

Sectional view GWE 5104

Technical Data

- T** = Transmissible torque at given T_A
- H_{es}** = Hardness of the elastomeric spider
- n_{max}** = Max. rotation speed
- J** = Total moment of inertia
- G_w** = Weight
- D_{G1}** = Thread
- T_{A1}** = Tightened torque of clamping screw D_{G1}

Transmissible torque T [Nm]

Size	Ø mm Ø inch																					
	5 0.197	6 0.236	8 0.315	10 0.394	12 0.472	14 0.551	16 0.630	20 0.787	25 0.984	30 1.181	35 1.378	40 1.575	45 1.772	50 1.989	55 2.165	60 2.362	65 2.560	70 2.756	80 3.150	90 3.543	95 3.740	
14	4	4	6	7	8	9	9	---	---	---	---	---	---	---	---	---	---	---	---	---	---	---
19	---	12	13	13	13	13	13	13	---	---	---	---	---	---	---	---	---	---	---	---	---	---
24	---	---	---	27	32	37	41	44	44	44	---	---	---	---	---	---	---	---	---	---	---	---
28	---	---	---	45	53	61	69	84	102	118	118	---	---	---	---	---	---	---	---	---	---	---
38	---	---	---	---	64	74	83	102	124	145	166	185	204	---	---	---	---	---	---	---	---	---
42	---	---	---	---	---	128	145	178	218	257	294	332	332	---	---	---	---	---	---	---	---	---
48	---	---	---	---	---	---	204	253	313	370	387	387	387	387	387	---	---	---	---	---	---	---
55	---	---	---	---	---	---	---	---	---	---	465	505	505	505	505	505	505	505	505	---	---	---
65	---	---	---	---	---	---	---	---	---	---	468	527	583	639	693	693	693	693	693	693	---	---
75	---	---	---	---	---	---	---	---	---	---	736	830	922	1010	1098	1183	1267	1350	1416	1416	1416	1416

Characteristics

- Hubs up to size 48 made of aluminum, from size 55 made of steel
- Hubs up to size 19 single slit, from size 24 double slit
- Standard elastomeric spider with 98 SH A (red spider), from size 65 with 95 SH A (yellow spider), optional with through bore hole see page 54/55
- The shaft tolerance should be within the fit tolerance "g6" or "h7"
- The contact surfaces have to be free from oil and grease

The torque values shown in the technical data tables can only be safely transmitted if all instructions are followed.

Dimensions

$d_1; d_{2min}$ = Min. bore diameter
 $d_1; d_{2max}$ = Max. bore diameter
 $d_{1k}; d_{2kmin}$ = Min. bore diameter with keyway acc. to DIN 6885-1
 $d_{1k}; d_{2kmax}$ = Max. bore diameter with keyway acc. to DIN 6885-1
 C_1 = Guided length in hub boring d_1
 D_1 = Outer diameter hub
 D_3 = Outer diameter hub
 H = Clearance diameter
 H_3 = Length of damping part
 l = Distance between center screw hole and hub end
 K = Distance shaft axis - clamping screw axis
 K_1 = Clamping length
 L = Total length
 L_3 = Section length of hub



Dimensions

Technical Data

Size	$d_1; d_2$ min-max	$d_{1k}; d_{2k}$ min-max																	
	Without keyway	With keyway	C_1	D_1	D_3	H	H_3	l	K	K_1	L	L_3	T	H_{es}	n_{max}	J	G_w	D_{G1}	T_{A1}
	inch	inch	inch	inch	inch	inch	inch	inch	inch	inch	inch	inch	ft-lbs		rpm	lbs-in ²	lbs	mm	ft-lbs
14	0.197 - 0.63	0.197 - 0.63	0.433	1.181	---	1.28	0.512	0.197	0.433	0.315	1.378	---	9	98 SH A	13000	0.021	0.09	2 x M3	1.5
19	0.236 - 0.787	0.236 - 0.787	0.984	1.575	---	1.811	0.63	0.276	0.571	0.472	2.598	---	13	98 SH A	10000	0.12	0.35	2 x M6	8
24	0.394 - 1.26	0.394 - 1.26	1.181	2.165	---	2.244	0.709	0.413	0.787	0.748	3.071	---	44	98 SH A	7000	0.51	0.67	2 x M8	11
28	0.394 - 1.496	0.394 - 1.496	1.378	2.559	---	2.795	0.787	0.453	0.965	0.846	3.543	---	118	98 SH A	6000	1.1	1.1	2 x M8	24
38	0.472 - 1.89	0.472 - 1.89	1.772	3.15	---	3.268	0.945	0.61	1.181	1.22	4.488	---	240	98 SH A	5000	3.3	2.1	2 x M8	28
42	0.551 - 2.126	0.551 - 2.126	1.969	3.74	3.346	3.74	1.024	0.709	1.28	1.26	4.961	1.102	332	98 SH A	4000	17	8.4	2 x M10	62
48	0.591 - 2.362	0.591 - 2.362	2.205	4.134	3.74	4.173	1.102	0.827	1.417	1.496	5.512	1.26	387	98 SH A	3600	28	11	2 x M12	107
55	1.378 - 2.913	1.378 - 2.913	2.559	4.724	---	4.724	1.181	1.024	1.772	1.831	6.299	---	505	98 SH A	3150	65	22	2 x M12	107
65	1.378 - 3.15	1.378 - 3.15	2.953	5.315	---	5.315	1.378	1.102	1.969	2.047	7.283	---	693	95 SH A	2800	105	30	2 x M12	107
75	1.181 - 3.74	1.181 - 3.74	3.346	6.299	---	6.299	1.575	1.417	2.362	2.579	8.268	---	1416	95 SH A	2350	228	47	2 x M16	218

Transmission of the couplings transmissible torque T can no longer be guaranteed for certain with borings $< d_{min}$. Types with borings $< d_{min}$, however, can be supplied. Moment of inertia and weight (mass) are calculated with reference to the largest bore size.

Ordering example: GWE 5106

Series Size	Bore diameter d_1	Bore diameter d_2	Further details*
GWE 5106-42	1.574	1.732	*

* Keyway

GERWAH® GWE 5106

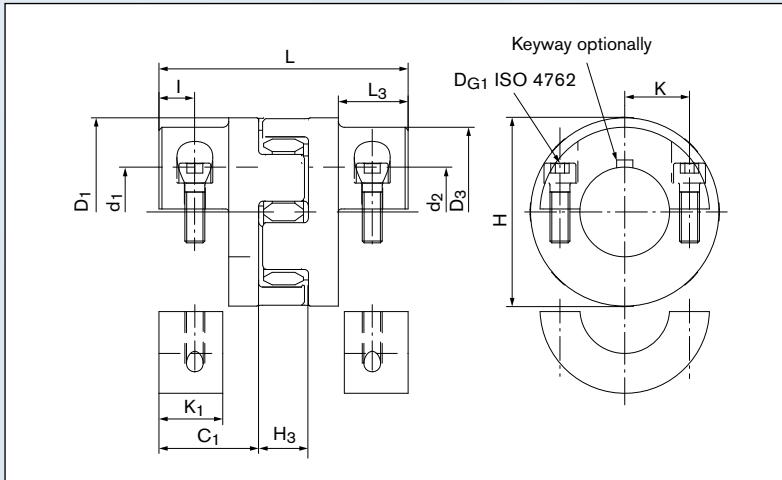

Sectional view GWE 5106

Technical Data

- T** = Transmissible torque at given T_A
- H_{es}** = Hardness of the elastomeric spider
- n_{max}** = Max. rotation speed
- J** = Total moment of inertia
- G_w** = Weight
- D_{G1}** = Thread
- T_{A1}** = Tightened torque of clamping screw D_{G1}

Transmissible torque T [Nm]

Size	Ø mm Ø inch																					
	5 0.197	6 0.236	8 0.315	10 0.394	12 0.472	14 0.551	16 0.630	20 0.787	25 0.984	30 1.181	35 1.378	40 1.575	45 1.772	50 1.989	55 2.165	60 2.362	65 2.560	70 2.756	80 3.150	90 3.543	95 3.740	
14	2.7	3.2	4	5	6	8	9	---	---	---	---	---	---	---	---	---	---	---	---	---	---	---
19	---	9	13	13	13	13	13	13	---	---	---	---	---	---	---	---	---	---	---	---	---	---
24	---	---	---	21	25	30	34	42	44	44	---	---	---	---	---	---	---	---	---	---	---	---
28	---	---	---	34	41	48	55	68	86	103	119	---	---	---	---	---	---	---	---	---	---	---
38	---	---	---	---	49	57	65	81	101	122	142	162	182	---	---	---	---	---	---	---	---	---
42	---	---	---	---	---	103	117	146	183	220	256	293	329	---	---	---	---	---	---	---	---	---
48	---	---	---	---	---	---	172	215	268	322	376	387	387	387	387	---	---	---	---	---	---	---
55	---	---	---	---	---	---	---	---	---	---	376	430	484	505	505	505	505	505	---	---	---	---
65	---	---	---	---	---	---	---	---	---	---	376	430	484	537	591	645	693	693	693	---	---	---
75	---	---	---	---	---	---	---	---	---	---	578	660	743	825	908	991	1073	1156	1320	1416	1416	---

Characteristics

- Hubs up to size 48 made of aluminum, from size 55 made of steel
- Standard elastomeric spider with 98 SH A (red spider), from size 65 with 95 SH A (yellow spider), optional with through bore hole see page 54/55
- The shaft tolerance should be within the fit tolerance "g6" or "h7"
- The contact surfaces have to be free from oil and grease

The torque values shown in the technical data tables can only be safely transmitted if all instructions are followed.

Dimensions

- $d_1; d_{2min}$ = Min. bore diameter
 $d_1; d_{2max}$ = Max. bore diameter
 C_1 = Guided length in hub boring d_1
 D_1 = Outer diameter hub
 H_3 = Length of damping part
 K_5 = Width of clamping ring
 L = Total length



Dimensions

Technical Data

Size	$d_1; d_2$ min-max Without keyway	C_1	D_1	H_3	K_5	L	T	H_{es}	n_{max}	J	Gw	D_{G1}	T_{A1}
14	0.236 - 0.551	0.728	1.26	0.512	0.315	1.969	9	98 SH A	25400	0.05	0.09	M3	1.3
19	0.315 - 0.787	0.984	1.575	0.63	0.394	2.598	13	98 SH A	19000	0.22	0.35	M4	2.2
24	0.433 - 0.984	1.181	2.165	0.709	0.512	3.071	44	98 SH A	13800	0.9	0.67	M5	4.5
28	0.591 - 1.417	1.378	2.559	0.787	0.63	3.543	118	98 SH A	11700	2.2	1.1	M5	4.5
38	0.787 - 1.614	1.772	3.15	0.945	0.866	4.488	240	98 SH A	9550	6.7	2.1	M6	7.5
42	0.984 - 1.969	1.969	3.74	1.024	0.984	5.276	332	98 SH A	8050	22	8.4	M8	26
48	1.102 - 2.165	2.205	4.134	1.102	1.102	5.512	387	98 SH A	7200	36	11	M10	51

Transmission of the couplings transmissible torque T can not longer be guaranteed for certain with borings < d_{min} . Types with borings < d_{min} , however, can be supplied. Moment of inertia and weight (mass) are calculated with reference to the largest bore size.

Ordering example: GWE 5112

Series Size	Bore diameter d_1	Bore diameter d_2	Further details*
GWE 5112-42	1.26	1.614	*

* Different spider shore hardness

GERWAH® GWE 5112

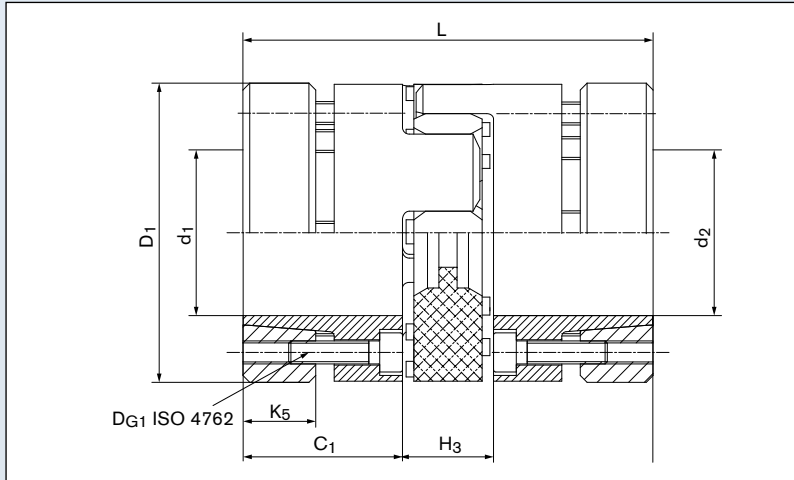

Sectional view GWE 5112

Technical Data

- T** = Transmissible torque at given T_A
- H_{es}** = Hardness of the elastomeric spider
- n_{max}** = Max. rotation speed
- J** = Total moment of inertia
- G_w** = Weight
- D_{G1}** = Thread
- T_{A1}** = Tightened torque of clamping screw D_{G1}

Transmissible torque T [Nm]

Size	Ø mm Ø inch																				
	6 0.236	10 0.394	11 0.433	13 0.512	14 0.551	15 0.591	17 0.670	19 0.748	20 0.787	24 0.945	25 0.984	27 1.063	30 1.181	32 1.260	36 1.417	38 1.496	42 1.654	44 1.732	48 1.890	50 1.989	55 2.165
14	2.7	7	9	9	9	---	---	---	---	---	---	---	---	---	---	---	---	---	---	---	---
19	---	13	13	13	13	13	13	13	13	---	---	---	---	---	---	---	---	---	---	---	---
24	---	---	16	27	34	41	44	44	44	44	44	---	---	---	---	---	---	---	---	---	---
28	---	---	---	---	---	41	50	84	99	118	118	118	118	118	118	---	---	---	---	---	---
38	---	---	---	---	---	---	---	---	99	170	193	240	240	240	240	240	---	---	---	---	---
42	---	---	---	---	---	---	---	---	---	---	192	243	332	332	332	332	332	332	332	332	---
48	---	---	---	---	---	---	---	---	---	---	---	240	332	387	387	387	387	387	387	387	387

Characteristics

- Hubs up to size 38 made of aluminum, from size 42 made of steel
- Clamping bush made of steel
- Standard elastomeric spider with 98 SH A (red spider), optional with through bore hole see page 54/55
- Optimal concentricity
- Easy to install
- The shaft tolerance should be within the fit tolerance "g6" or "h7"
- The contact surfaces have to be free from oil and grease

The torque values shown in the technical data tables can only be safely transmitted if all instructions are followed.

Technical Information Servo-Insert Couplings

Backlash-free Servo-Insert Couplings

Technical description

The couplings can be fine tuned to the specific application requirements in terms of torsional stiffness and vibration behaviour by selecting from various colour coded elastomeric spiders having different grades of shore hardness.

Technical terms for the coupling design

Pre-Compression:

The elastic pre-compression varies in dependence from the shore hardness of spiders, the size of the coupling and the machining tolerances. From this the axial insertion force results: From light (as a push fit with torsionally soft spider) to heavy (with high pre-compression with torsionally stiff spider).

T_N – Nominal torque of coupling (Nm):

Continuous torque which can be transmitted throughout the entire speed range, taking into consideration operational factors such as ambient temperatures and torsional stiffness.

T_{max} – Maximum torque of coupling (Nm):

Torque which can be transmitted $>10^5$ time as a peak load or $5 \cdot 10^4$ times as an alternating load during the entire life of the coupling taking into consideration factors such as temperatures, torsional stiffness and shock loading.

Spider Durometer (shore hardness)	Colour	Material	Allowable temperature °F		Available for size	Typical applications
			Continuous temperature	Max. temp. short term		
80 SH A	blue	Polyurethane	-58 to +176	-76 to +248	5-19	Drives in electronic measuring systems; backlash-free when pre-compressed
92 SH A	yellow	Polyurethane	-40 to +194	-58 to +248	5-55	Main spindle drives; backlash-free when pre-compressed
*95/98 SH A	red	Polyurethane	-22 to +194	-40 to +248	5-75	Positioning drives; backlash-free when pre-compressed
64 SH D-H	green	Hytrel	-58 to +248	-76 to +302	7-38	Machine tool spindles, control drives, lead units, planetary gearboxes; heavy loads, torsionally stiff, high ambient temperature, water proof
64 SH D	green	Polyurethane	-4 to +230	-22 to +248	42-75	

* From size 65 \geq 95° A

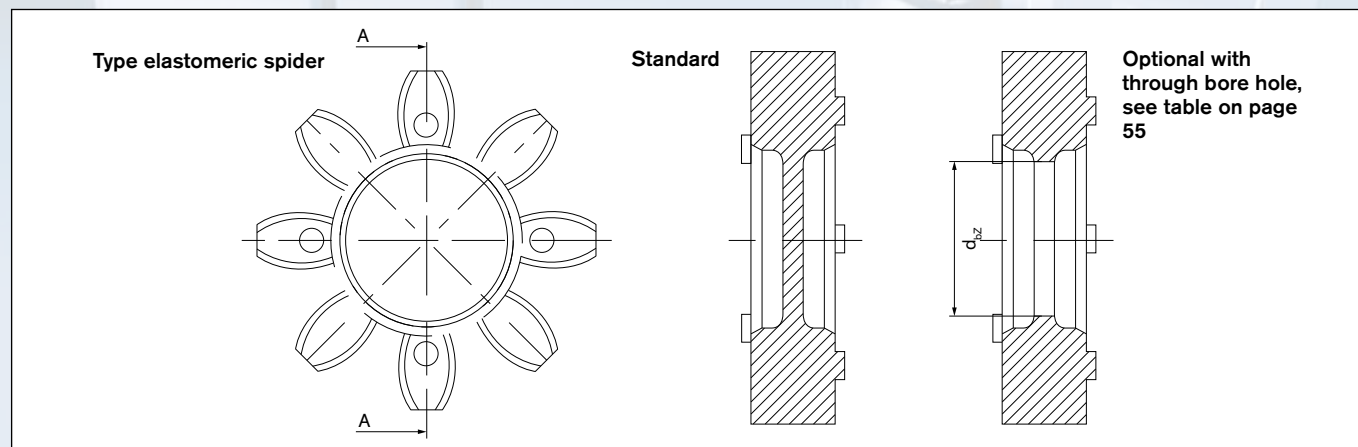

Technical Information Servo-Insert Couplings

Technical Information Spiders

Size	Sh	η_{max}	η_{max}	η_{max}	η_{max}	η_{max}	T_N	T_{max}	C_{Tstat}	C_{Tdyn}	C_r	d_{bz}	ΔKa	ΔKr	ΔKw
		(5102)	(5103)	(5103.1)	(5104)	(5112)									
		min ⁻¹	min ⁻¹	min ⁻¹	min ⁻¹	min ⁻¹	ft-lbs	ft-lbs	ft-lbs/rad	10 ³ ft-lbs/rad	lbs/inch	inch	inch	inch	degree
5	80 Sh A	47500	---	38000	---	---	0.22	0.44	2.4	7.4	468	---	0.016/-0.008	0.005	1.1
5	92 Sh A	47500	---	3800	---	---	0.37	0.74	3.8	12	879	---	0.016/-0.008	0.002	1
5	98 Sh A	47500	---	38000	---	---	0.66	1.3	6.1	18	1690	---	0.016/-0.008	0.002	0.9
7	64 Sh D-H	34000	27000	27000	---	---	1.8	3.5	25	76	3597	---	0.024/-0.012	0.002	0.8
7	80 Sh A	34000	27000	27000	---	---	0.5	1.0	6.3	19	651	---	0.024/-0.012	0.006	1.1
7	92 Sh A	34000	27000	27000	---	---	0.9	1.8	11	32	1251	---	0.024/-0.012	0.004	1
7	98 Sh A	34000	27000	27000	---	---	1.5	3.0	17	51	2404	---	0.024/-0.012	0.002	0.9
9	64 Sh D-H	24000	19000	19000	---	---	4.4	8.9	55	165	4391	0.256	0.031/-0.016	0.002	0.8
9	80 Sh A	24000	19000	19000	---	---	1.3	2.7	13	38	714	0.256	0.031/-0.016	0.035	1.1
9	92 Sh A	24000	19000	19000	---	---	2.2	4.4	23	70	1496	0.256	0.031/-0.016	0.005	1
9	98 Sh A	24000	19000	19000	---	---	3.7	7.4	38	114	2958	0.256	0.031/-0.016	0.003	0.9
12	64 Sh D-H	19000	15000	---	---	---	8.9	17.7	242	724	6841	0.295	0.035/-0.016	0.002	0.8
12	80 Sh A/	19000	15000	---	---	---	2.2	4.4	62	186	1565	0.295	0.035/-0.016	0.008	1.1
12	92 Sh A	19000	15000	---	---	---	3.7	7.4	118	355	2684	0.295	0.035/-0.016	0.006	1
12	98 Sh A	19000	15000	---	---	---	6.6	13.3	178	530	4831	0.295	0.035/-0.016	0.003	0.9
14	64 Sh D-H	16000	13000	---	13000	25400	12	24	173	518	4888	0.335	0.039/-0.02	0.002	0.8
14	80 Sh A	16000	13000	---	13000	25400	3.0	5.9	44	133	874	0.335	0.039/-0.02	0.008	1.1
14	92 Sh A	16000	13000	---	13000	25400	5.5	11	85	254	1919	0.335	0.039/-0.02	0.006	1
14	98 Sh A	16000	13000	---	13000	25400	9.2	18	127	378	3734	0.335	0.039/-0.02	0.004	0.9
19	64 Sh D-H	12000	10000	---	10000	19000	15	31	915	2744	16731	0.630	0.047/-0.02	0.002	0.8
19	80 Sh A	12000	10000	---	10000	19000	3.7	7.4	251	760	3323	0.630	0.047/-0.02	0.006	1.1
19	92 Sh A	12000	10000	---	10000	19000	7.4	15	420	1269	6395	0.630	0.047/-0.02	0.004	1
19	98 Sh A	12000	10000	---	10000	19000	12.5	25	634	1903	11477	0.630	0.047/-0.02	0.002	0.9
24	64 Sh D-H	8500	7000	---	7000	13800	55	111	2198	6589	21105	0.945	0.055/-0.02	0.003	0.8
24	92 Sh A	8500	7000	---	7000	13800	26	52	1055	3169	8451	0.945	0.055/-0.02	0.006	1
24	98 Sh A	8500	7000	---	7000	13800	44	89	1519	4565	14618	0.945	0.055/-0.02	0.004	0.9
28	64 Sh D-H	7300	6000	---	6000	11700	148	295	3208	9625	24828	1.063	0.059/-0.028	0.003	0.8
28	92 Sh A	7300	6000	---	6000	11700	70	140	1689	5072	10164	1.063	0.059/-0.028	0.006	1
28	98 Sh A	7300	6000	---	6000	11700	118	236	2537	7607	18273	1.063	0.059/-0.028	0.004	0.9
38	64 Sh D-H	5900	5000	---	5000	9550	299	597	7774	23322	36968	1.378	0.071/-0.028	0.004	0.8
38	92 Sh A	5900	5000	---	5000	9550	140	280	3378	10143	13419	1.378	0.071/-0.028	0.007	1
38	98 Sh A	5900	5000	---	5000	9550	240	479	5281	15847	25125	1.378	0.071/-0.028	0.005	0.9
42	64 Sh D	---	4000	---	4000	8050	413	826	20342	52883	41513	1.654	0.079/-0.039	0.004	0.8
42	92 Sh A	---	4000	---	4000	8050	195	391	4647	17922	13876	1.654	0.079/-0.039	0.007	1
42	98 Sh A	---	4000	---	4000	8050	332	664	14161	35403	33861	1.654	0.079/-0.039	0.006	0.9
48	64 Sh D	---	3600	---	3600	7200	483	966	26700	66750	47246	1.811	0.083/-0.039	0.004	0.8
48	92 Sh A	---	3600	---	3600	7200	229	457	5790	13317	14732	1.811	0.083/-0.039	0.009	1
48	98 Sh A	---	3600	---	3600	7200	387	774	16499	41248	33861	1.811	0.083/-0.039	0.006	0.9
55	64Sh D	---	3150	---	3150	---	608	1217	77983	96032	52808	---	0.087/-0.039	0.005	0.8
55	92Sh A	---	3150	---	3150	---	302	605	11419	15766	17016	---	0.087/-0.039	0.009	1
55	98Sh A	---	3150	---	3150	---	505	1010	31064	45398	38178	---	0.087/-0.039	0.007	0.9
65	64Sh D	---	2800	---	2800	---	867	1217	87410	139540	50649	---	0.1/-0.039	0.005	0.8
65	95Sh A	---	2800	---	2800	---	693	1387	357870	52854	36648	---	0.1/-0.039	0.007	0.9
75	64Sh D	---	2350	---	2350	---	1770	3540	134474	233351	68082	---	0.118/-0.059	0.006	0.8
75	95Sh A	---	2350	---	2350	---	1416	2832	58379	110968	49393	---	0.118/-0.059	0.008	0.9

ISO Tolerances

Shafts

Nominal diameter of shaft		d11		e8		e7		f8		f7		g6		h11		h9		h8		h7	
mm		µm		µm		µm		µm		µm		µm		µm		µm		µm		µm	
above	to	upper	lower	upper	lower	upper	lower	upper	lower	upper	lower	upper	lower	upper	lower	upper	lower	upper	lower	upper	lower
3	6	- 30	- 105	- 20	- 38	- 20	- 32	- 10	- 28	- 10	- 22	- 4	- 12	0	- 75	0	- 30	0	- 18	0	- 12
6	10	- 40	- 130	- 25	- 47	- 25	- 40	- 13	- 35	- 13	- 28	- 5	- 14	0	- 90	0	- 36	0	- 22	0	- 15
10	18	- 50	- 160	- 32	- 59	- 32	- 50	- 16	- 43	- 16	- 34	- 6	- 17	0	- 110	0	- 43	0	- 27	0	- 18
18	30	- 65	- 195	- 40	- 73	- 40	- 61	- 20	- 53	- 20	- 42	- 7	- 20	0	- 130	0	- 52	0	- 33	0	- 21
30	50	- 80	- 240	- 50	- 89	- 50	- 75	- 25	- 64	- 25	- 50	- 9	- 25	0	- 160	0	- 62	0	- 39	0	- 25
50	80	- 100	- 290	- 60	- 106	- 60	- 90	- 30	- 76	- 30	- 60	- 10	- 29	0	- 190	0	- 74	0	- 46	0	- 30
80	120	- 120	- 340	- 72	- 126	- 72	- 107	- 36	- 90	- 36	- 71	- 12	- 34	0	- 220	0	- 87	0	- 54	0	- 35
120	180	- 145	- 395	- 85	- 148	- 85	- 125	- 43	- 106	- 43	- 83	- 14	- 39	0	- 250	0	- 100	0	- 63	0	- 40
180	250	- 170	- 460	- 100	- 172	- 100	- 146	- 50	- 122	- 50	- 96	- 15	- 44	0	- 290	0	- 115	0	- 72	0	- 46
250	315	- 190	- 510	- 110	- 191	- 110	- 162	- 56	- 137	- 56	- 108	- 17	- 49	0	- 320	0	- 130	0	- 81	0	- 52
315	400	- 210	- 570	- 125	- 214	- 125	- 182	- 62	- 151	- 62	- 119	- 18	- 54	0	- 360	0	- 140	0	- 89	0	- 57
400	500	- 230	- 630	- 135	- 232	- 135	- 198	- 68	- 165	- 68	- 131	- 20	- 60	0	- 440	0	- 155	0	- 97	0	- 63
500	630	- 260	- 700	- 145	- 255	- 145	- 215	- 76	- 186	- 76	- 146	- 22	- 66	0	- 440	0	- 175	0	- 110	0	- 70
630	800	- 290	- 790	- 160	- 285	- 160	- 240	- 80	- 205	- 80	- 160	- 24	- 74	0	- 500	0	- 200	0	- 125	0	- 80

Nominal diameter of shaft		h6		h5		j6		k6		k5		m6		m5		n6		p6	
mm		µm		µm		µm		µm		µm		µm		µm		µm		µm	
above	to	upper	lower	upper	lower	upper	lower	upper	lower	upper	lower	upper	lower	upper	lower	upper	lower	upper	lower
3	6	0	- 8	0	- 5	+ 7	- 1	-	-	-	-	+ 12	+ 4	+ 9	+ 4	+ 16	+ 8	+ 20	+ 12
6	10	0	- 9	0	- 6	+ 7	- 2	+ 10	+ 1	+ 7	+ 1	+ 15	+ 6	+ 12	+ 6	+ 19	+ 10	+ 24	+ 15
10	18	0	- 11	0	- 8	+ 8	- 3	+ 12	+ 1	+ 9	+ 1	+ 18	+ 7	+ 15	+ 7	+ 23	+ 12	+ 29	+ 18
18	30	0	- 13	0	- 9	+ 9	- 4	+ 15	+ 2	+ 11	+ 2	+ 21	+ 8	+ 17	+ 8	+ 28	+ 15	+ 35	+ 26
30	50	0	- 16	0	- 11	+ 11	- 5	- 18	+ 2	+ 13	+ 2	+ 25	+ 9	+ 20	+ 9	+ 33	+ 17	+ 42	+ 26
50	80	0	- 19	0	- 13	+ 12	- 7	+ 21	+ 2	+ 15	+ 2	+ 30	+ 11	+ 24	+ 11	+ 39	+ 20	+ 51	+ 32
80	120	0	- 22	0	- 15	+ 13	- 9	+ 25	+ 3	+ 18	+ 3	+ 35	+ 13	+ 28	+ 13	+ 45	+ 23	+ 59	+ 37
120	180	0	- 25	0	- 18	+ 14	- 11	+ 28	+ 3	+ 21	+ 3	+ 40	+ 15	+ 33	+ 15	+ 52	+ 27	+ 68	+ 43
180	250	0	- 29	0	- 20	+ 16	- 13	+ 33	+ 4	+ 24	+ 4	+ 46	+ 17	+ 37	+ 17	+ 60	+ 31	+ 79	+ 50
250	315	0	- 32	0	- 23	+ 16	- 16	+ 36	+ 4	+ 27	+ 4	+ 53	+ 20	+ 43	+ 20	+ 66	+ 34	+ 88	+ 56
315	400	0	- 36	0	- 25	+ 18	- 18	+ 40	+ 4	+ 29	+ 4	+ 57	+ 21	+ 46	+ 21	+ 73	+ 37	+ 98	+ 62
400	500	0	- 40	0	- 27	+ 20	- 20	+ 45	+ 5	+ 32	+ 5	+ 63	+ 23	+ 50	+ 23	+ 80	+ 40	+ 108	+ 68
500	630	0	- 44	0	- 28	-	-	+ 44	0	-	-	+ 70	+ 26	-	-	+ 88	+ 44	+ 122	+ 78
630	800	0	- 50	0	- 32	-	-	+ 50	0	-	-	+ 80	+ 30	-	-	+ 100	+ 50	+ 138	+ 88

Line Shafts Basics

Backlash-free Line Shafts Series

Torsionally stiff and flexible line shafts are used in applications, where torque and rotational motion combined with the highest possible angular precision should be transmitted or considerable distances between shafts need to be bridged. The application range of line shafts covers almost all technical areas, where mechanical power transmission and stiffness are important:

Torsionally flexible line shafts with elastomeric spider

- Absolutely backlash-free
- Installation length up to 13.12 ft possible
- Compensation of axial, radial and angular misalignment
- Cost-effective, simple assembly
- Maintenance-free
- Variable length of the intermediate steel or aluminum tube
- Backlash-free elastomeric spider
- Excellent transmission of torque and compensation of misalignment
- High transmission accuracy
- Temperature range -22° F to +248° F

Torsionally stiff line shafts with metal bellows

- Absolutely backlash-free
- Installation length up to 13.12 ft possible
- Compensation of axial, radial and angular misalignment
- Aluminum lightweight construction up to size 200
- Optional with CFK-tube
- Maintenance-free, no wear
- Cardanical structure
- Special stainless steel bellows
- Excellent power transmission
- High torsional stiffness and misalignment compensation
- Optimal moment of inertia
- Additional balancing holes for better concentricity
- Temperature range -22° F to +212° F
- High precision of rotation angle

Packaging Machine



Overview Line Shafts



GERWAH®
GWZ 5104.1

Servo-insert coupling with clamping hubs

Page 60



GERWAH®
GWZ 5106.1

Servo-insert coupling with clamping hubs in half shell construction

Page 62



GERWAH®
GWZ 5116

Metal bellows coupling with clamping hubs in flange construction

Page 64



GERWAH®
GWZ 5106

Metal bellows coupling with clamping hubs in split hub design

Page 66

Dimensions

$d_1; d_{2min}$	= Min. bore diameter
$d_1; d_{2max}$	= Max. bore diameter
$d_{1k}; d_{2kmin}$	= Min. bore diameter with keyway acc. to DIN 6885-1
$d_{1k}; d_{2kmax}$	= Max. bore diameter with keyway acc. to DIN 6885-1
C_1	= Guided length in hub boring d_1
D_1	= Outer diameter hub
D_5	= Tube diameter
H	= Clearance diameter
H_3	= Length of damping part
I	= Distance between center screw hole and hub end
K	= Distance shaft axis - clamping screw axis
K_1	= Clamping length
L_1	= Length of coupling
L_{3min}	= Min. length of inside shaft
L_{3max}	= Max. length of inside shaft

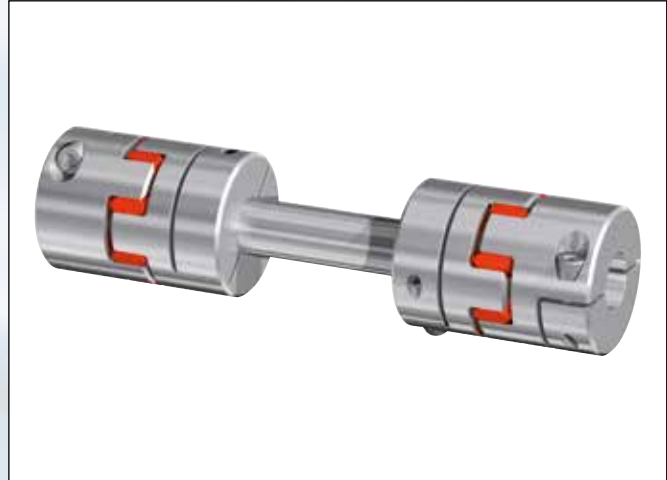

Dimensions

Size	$d_1; d_2$ min-max		$d_{1k}; d_{2k}$ min-max		C_1	D_1	D_5	H	H_3	I	K	K_1	L_1	L_3 min-max
	Without keyway	With keyway	Without keyway	With keyway										
	inch	inch	inch	inch										inch
14	0.197 - 0.630	0.197 - 0.630	0.433	1.181	0.630	1.244	0.512	0.197	0.433	0.433	1.378	3.150 - 78.740		
19	0.236 - 0.787	0.236 - 0.787	0.984	1.575	0.787	1.811	0.630	0.472	0.571	0.984	2.598	5.315 - 78.740		
24	0.394 - 1.260	0.394 - 1.260	1.181	2.165	0.984	2.244	0.709	0.413	0.787	0.748	3.071	6.299 - 78.740		
28	0.394 - 1.496	0.394 - 1.496	1.378	2.559	1.181	2.795	0.787	0.453	0.965	0.846	3.543	7.283 - 78.740		
38	0.472 - 1.890	0.472 - 1.890	1.772	3.150	1.575	3.268	0.945	0.610	1.181	1.220	4.488	9.055 - 78.740		
42	0.551 - 2.126	0.551 - 2.126	1.969	3.740	1.575	3.740	1.024	0.709	1.280	1.260	4.961	10.039 - 78.740		
48	0.591 - 2.362	0.591 - 2.362	2.205	4.134	1.969	4.114	1.102	0.827	1.417	1.496	5.512	11.417 - 78.740		

Transmission of the couplings transmissible torque T can no longer be guaranteed for certain with borings $< d_{min}$. Types with borings $< d_{min}$, however, can be supplied.

Characteristics

- Hubs made of aluminum
- Hubs up to size 19 simple slit, from size 24 double slit
- Precision hollow shaft made of steel
- Standard elastomeric spider with 98 SH A (red spider), optional with through bore hole see page 54/55
- Fail-safe design
- The shaft tolerance should be within the fit tolerance "g6" or "h7"
- The contact surfaces have to be free from oil and grease

The torque values shown in the technical data tables can only be safely transmitted if all instructions are followed.

Ordering example: GWZ 5104.1

Series Size	Total length L	Bore diameter d_1	Bore diameter d_2	Further details*
GWZ 5104.1-14	9.843	0.394	0.551	*

* Keyway

GERWAH® GWZ 5104.1

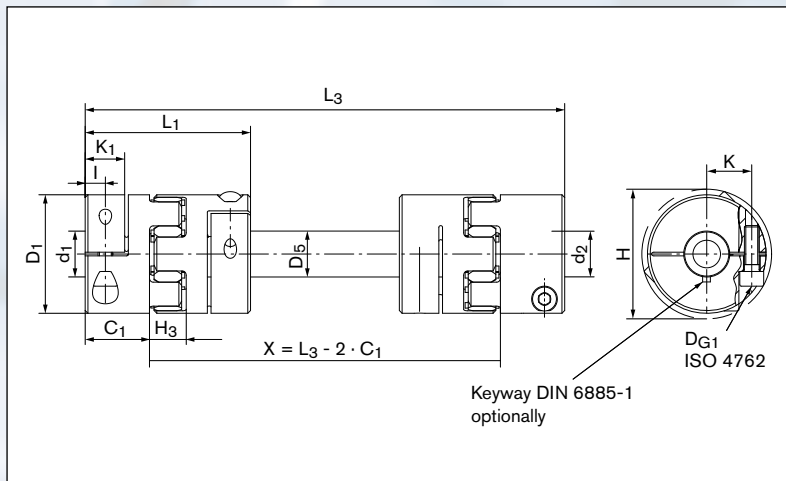

Sectional view GWZ 5104.1

Technical Data

- T** = Transmissible torque at given T_A
- H_{es}** = Hardness of the elastomeric spider
- C_m** = Torsional stiffness of extension tube per meter
- D_{G1}** = Thread
- T_{A1}** = Tightened torque of clamping screw D_{G1}

Technical Data

Size	T	H _{es}	C _m	D _{G1}	T _{A1}
	ft-lbs		ft-lbs/rad	mm	ft-lbs
14	9	98 SH A	376	1 x M3	1.5
19	13	98 SH A	712	1 x M6	8
24	44	98 SH A	1943	1 x M6	11
28	118	98 SH A	4093	1 x M8	24
38	240	98 SH A	11410	1 x M8	28
42	332	98 SH A	11410	1 x M10	62
48	387	98 SH A	32095	1 x M12	107

Transmissible torque T [Nm]

Size	Ø mm Ø Inch																				
	5 0.197	6 0.236	8 0.315	9 0.354	10 0.394	12 0.472	14 0.551	15 0.591	16 0.630	18 0.707	20 0.787	22 0.866	24 0.945	25 0.984	30 1.181	35 1.378	40 1.575	45 1.772	50 1.989	55 2.165	58 2.283
14	4	4	6	6	7	8	8	8	8	---	---	---	---	---	---	---	---	---	---	---	---
19	---	12	13	13	13	13	13	13	13	13	13	---	---	---	---	---	---	---	---	---	---
24	---	---	---	---	27	32	37	39	41	44	44	44	44	44	44	---	---	---	---	---	---
28	---	---	---	---	45	53	61	65	69	77	84	91	99	102	118	118	---	---	---	---	---
38	---	---	---	---	---	64	74	79	83	93	102	111	120	124	145	166	185	204	---	---	---
42	---	---	---	---	---	---	128	137	145	162	178	195	210	218	257	294	332	332	---	---	---
48	---	---	---	---	---	---	---	---	204	228	253	277	301	313	370	387	387	387	387	387	387

Dimensions

$d_1; d_{2min}$	= Min. bore diameter
$d_1; d_{2max}$	= Max. bore diameter
$d_{1k}; d_{2kmin}$	= Min. bore diameter with keyway acc. to DIN 6885-1
$d_{1k}; d_{2kmax}$	= Max. bore diameter with keyway acc. to DIN 6885-1
C_1	= Guided length in hub boring d_1
D_1	= Outer diameter hub
D_5	= Tube diameter
H	= Clearance diameter
H_3	= Length of damping part
I	= Distance between center screw hole and hub end
K	= Distance shaft axis - clamping screw axis
K_1	= Clamping length
L_{3min}	= Min. length of inside shaft
L_{3max}	= Max. length of inside shaft



Dimensions

Size	$d_1; d_2$ min-max		$d_{1k}; d_{2k}$ min-max									L_3 min-max
	Without keyway	With keyway	C_1	D_1	D_5	H	H_3	I	K	K_1		
	inch	inch	inch	inch	inch						inch	
14	0.197 - 0.630	0.197 - 0.630	0.433	1.181	1.181	1.260	0.512	0.197	0.433	0.354	3.346 - 118.110	
19	0.236 - 0.787	0.236 - 0.787	1.004	1.575	1.575	1.811	0.630	315.000	0.571	0.748	5.748 - 118.110	
24	0.394 - 1.260	0.394 - 1.260	1.181	2.165	1.969	2.244	0.709	0.413	0.787	0.827	7.087 - 118.110	
28	0.394 - 1.496	0.394 - 1.496	1.378	2.559	2.362	2.795	0.787	0.433	0.965	0.925	8.504 - 118.110	
38	0.472 - 1.890	0.472 - 1.890	1.772	3.150	3.150	3.268	0.945	0.610	1.181	1.299	10.472 - 118.110	
42	0.551 - 2.126	0.551 - 2.126	1.969	3.740	3.543	3.740	1.024	0.709	1.280	1.378	11.024 - 118.110	
48	0.591 - 2.362	0.591 - 2.362	2.264	4.134	3.937	4.114	1.102	0.827	1.457	1.614	11.654 - 118.110	

Transmission of the couplings transmissible torque T can not longer be guaranteed for certain with borings $< d_{min}$. Types with borings $< d_{min}$, however, can be supplied.

Characteristics

- Hubs made of aluminum
- Standard elastomeric spider with 98 SH A (red spider), optional with through bore hole see page 54/55
- Precision line shaft made of aluminum
- Fail-safe design
- The shaft tolerance should be within the fit tolerance "g6" or "h7"
- The contact surfaces have to be free from oil and grease

The torque values shown in the technical data tables can only be safely transmitted if all instructions are followed.

Ordering example: GWZ 5106.1

Series Size	Total length L	Bore diameter d_1	Bore diameter d_2	Further details*
GWZ 5106.1-14	7.874	0.394	0.551	*

* Keyway

GERWAH® GWZ 5106.1

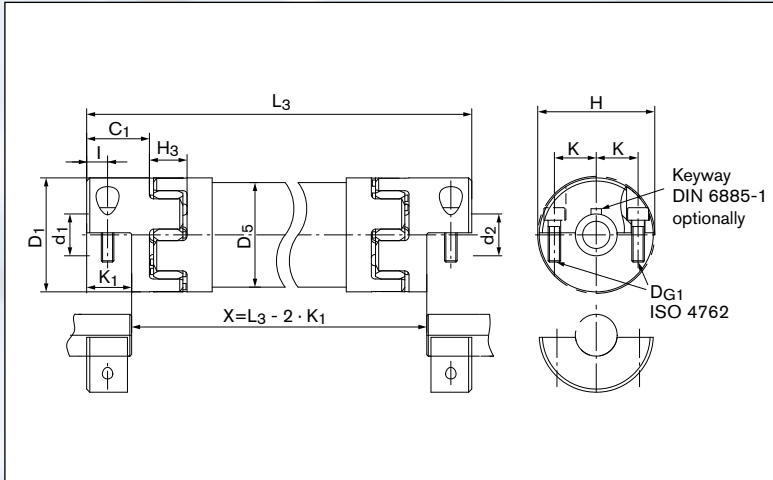

Sectional view GWZ 5106.1

Technical Data

- T** = Transmissible torque at given T_A
- H_{es}** = Hardness of the elastomeric spider
- C_m** = Torsional stiffness of extension tube per meter
- D_{G1}** = Thread
- T_{A1}** = Tightened torque of clamping screw D_{G1}

Technical Data

Size	T	H _{es}	C _m	D _{G1}	T _{A1}
	ft-lbs		ft-lbs/rad	mm	ft-lbs
14	9	98 SH A	1126	2 x M3	1.5
19	13	98 SH A	2393	2 x M6	8
24	44	98 SH A	4891	2 x M6	11
28	118	98 SH A	8714	2 x M8	24
38	240	98 SH A	33138	2 x M8	28
42	332	98 SH A	55905	2 x M10	62
48	387	98 SH A	67235	2 x M12	107

Transmissible torque T [Nm]

Size	Ø mm Ø inch																				
	5 0.197	6 0.236	8 0.315	9 0.354	10 0.394	12 0.472	14 0.551	15 0.591	16 0.630	18 0.707	20 0.787	22 0.866	24 0.945	25 0.984	30 1.181	35 1.378	40 1.575	44 1.732	48 1.890	50 1.989	58 2.283
14	3	3	4	5	5	6	8	8	9	---	---	---	---	---	---	---	---	---	---	---	---
19	---	9	13	13	13	13	13	13	13	13	13	---	---	---	---	---	---	---	---	---	---
24	---	---	---	---	21	25	30	32	34	38	42	44	44	44	44	---	---	---	---	---	---
28	---	---	---	---	---	41	48	51	55	61	68	75	82	86	103	119	---	---	---	---	---
38	---	---	---	---	---	49	57	60	65	73	81	89	97	101	122	142	162	182	---	---	---
42	---	---	---	---	---	---	103	110	117	132	146	161	176	183	220	256	293	329	---	---	---
48	---	---	---	---	---	---	---	---	172	193	215	237	258	190	322	376	387	387	387	387	387

Dimensions

$d_1; d_{2min}$	= Min. bore diameter
$d_1; d_{2max}$	= Max. bore diameter
$d_{1k}; d_{2kmin}$	= Min. bore diameter with keyway acc. to DIN 6885-1
$d_{1k}; d_{2kmax}$	= Max. bore diameter with keyway acc. to DIN 6885-1
A	= Max. outer diameter
C	= Pitch circle diameter
C_1	= Guided length in hub boring d_1
D_1	= Outer diameter hub
D_5	= Tube diameter
H	= Clearance diameter
I	= Distance between center screw hole and hub end
K	= Distance shaft axis - clamping screw axis
K_1	= Clamping length
L_1	= Length of coupling
L_{3min}	= Min. length of inside shaft
L_{3max}	= Max. length of inside shaft
L_6	= Length of basic part



Dimensions

Size	$d_1; d_2$ min-max		$d_{1k}; d_{2k}$ min-max		A	C	C_1	D_1	D_5	H	I	K	K_1	L_1	L_3 min-max	L_6
	Without keyway	With keyway														
	inch	inch	inch													
18	0.315 - 0.984	0.315 - 0.866	2.283	1.969	0.768	1.772	1.575	1.890	0.236	0.689	0.027	2.067	5.709 - 118.110	1.732		
30	0.394 - 0.984	0.394 - 0.866	2.756	2.441	0.965	2.165	1.969	2.205	0.315	0.787	0.031	2.067	5.827 - 118.110	1.614		
60	0.472 - 1.378	0.472 - 1.142	3.150	2.835	1.142	2.520	2.362	2.638	0.394	0.945	0.037	2.461	7.165 - 118.110	1.969		
150	0.551 - 1.575	0.551 - 1.417	4.055	3.622	1.299	3.150	3.149	3.307	0.472	1.102	0.042	3.346	9.094 - 118.110	2.244		
200	0.866 - 1.732	0.866 - 1.496	4.409	3.976	1.476	3.543	3.543	3.661	0.512	1.220	0.048	3.110	9.331 - 118.110	2.441		
300	0.945 - 1.890	0.945 - 1.654	5.394	4.803	1.476	4.331	4.252	4.331	0.512	1.535	0.060	3.248	9.606 - 118.110	2.598		
500	1.378 - 2.441	1.378 - 2.126	5.827	5.276	1.614	4.685	4.488	4.803	0.591	1.693	0.067	3.484	10.629 - 118.110	2.756		

Transmission of the couplings transmissible torque T can not longer be guaranteed for certain with borings < d_{min} . Types with borings < d_{min} , however, can be supplied.

Characteristics

- Metal bellows made of stainless steel, hubs made of aluminum
- Precision line shaft made of aluminum
- Optional line shaft made of CFK
- Backlash-free and torsionally rigid
- The shaft tolerance should be within the fit tolerance "g6" or "h7"
- The contact surfaces have to be free from oil and grease

The torque values shown in the technical data tables can only be safely transmitted if all instructions are followed.

Ordering example: GWZ 5116

Series Size	Total length	Bore diameter d_1	Bore diameter d_2	Further details*
GWZ 5116 18	19.685	0.394	0.984	*

* Keyway or stainless steel

GERWAH® GWZ 5116

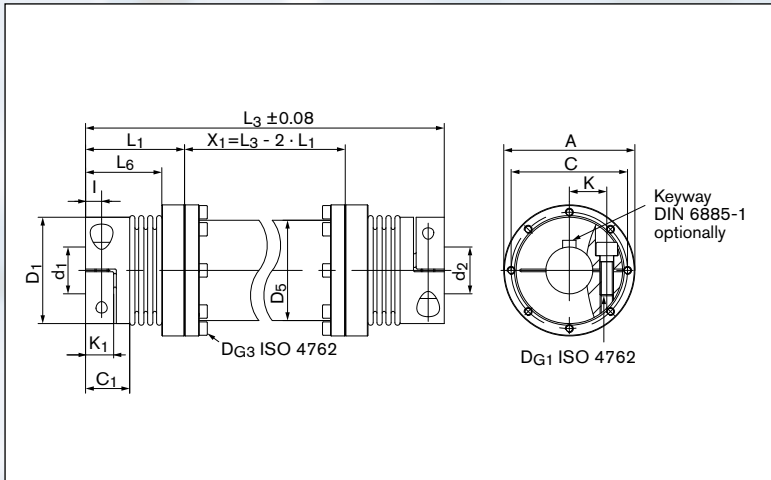

Sectional view GWZ 5116

Technical Data

- T** = Transmissible torque at given T_A
- C_m** = Torsional stiffness of extension tube per meter
- D_{G1}** = Thread
- T_{A1}** = Tightened torque of clamping screw D_{G1}
- D_{G3}** = Thread of the flange screws
- T_{A3}** = Tightening torque of the flange bolts D_{G3}

Technical Data

Size	T	C_m	D_{G1}	T_{A1}	D_{G3}	T_{A3}
	ft-lbs	ft-lbs/rad	mm	ft-lbs	mm	ft-lbs
18	22	2392	1 x M5	4	4 x M4	2.2
30	36	4892	1 x M6	9	6 x M4	3.0
60	75	8714	1 x M8	22	6 x M5	5.2
150	180	33138	1 x M10	63	8 x M6	7.0
200	240	55906	1 x M12	74	8 x M6	9.0
300	360	137714	1 x M12	89	8 x M8	22.0
500	600	149876	1 x M14	140	8 x M8	22.0

Transmissible torque T [Nm]

Size	Ø mm Ø inch																				
	8 0.315	9 0.354	10 0.394	11 0.433	12 0.472	13 0.512	15 0.591	16 0.630	18 0.707	20 0.787	22 0.866	25 0.984	28 1.102	30 1.181	35 1.378	40 1.575	45 1.772	50 1.989	55 2.165	60 2.362	64 2.520
18	13	15	16	16	16	16	16	16	16	16	16	16	---	---	---	---	---	---	---	---	---
30	---	---	27	27	27	27	27	27	27	27	27	27	27	27	---	---	---	---	---	---	---
60	---	---	---	---	55	55	55	55	55	55	55	55	55	55	55	---	---	---	---	---	---
150	---	---	---	---	---	---	133	133	133	133	133	133	133	133	133	133	---	---	---	---	---
200	---	---	---	---	---	---	---	---	---	---	177	177	177	177	177	177	177	---	---	---	---
300	---	---	---	---	---	---	---	---	---	---	---	266	266	266	266	266	266	266	266	266	---
500	---	---	---	---	---	---	---	---	---	---	---	---	---	---	443	443	443	443	443	443	443

Dimensions

$d_1; d_{2min}$	= Min. bore diameter
$d_1; d_{2max}$	= Max. bore diameter
$d_{1k}; d_{2kmin}$	= Min. bore diameter with keyway acc. to DIN 6885-1
$d_{1k}; d_{2kmax}$	= Max. bore diameter with keyway acc. to DIN 6885-1
C_1	= Guided length in hub boring d_1
D_1	= Outer diameter hub
D_5	= Tube diameter
H	= Clearance diameter
I	= Distance between center screw hole and hub end
K	= Distance shaft axis - clamping screw axis
K_1	= Clamping length
L_{3min}	= Min. length of inside shaft
L_{3max}	= Max. length of inside shaft
L_6	= Length of basic part



Dimensions

Size	$d_1; d_2$ min-max		$d_{1k}; d_{2k}$ min-max		C_1	D_1	D_5	H	I	K	K_1	L_3 min-max	L_6
	Without keyway	With keyway											
	inch	inch	inch	inch									
18	0.315 - 0.984	0.315 - 0.866	0.787	1.772	1.575	1.870	0.236	0.689	0.433	5.276 - 118.110	2.087		
30	0.394 - 0.984	0.394 - 0.866	0.965	2.165	1.969	2.205	0.315	0.787	0.591	5.236 - 118.110	2.047		
60	0.472 - 1.378	0.472 - 1.142	1.142	2.520	2.362	2.618	0.394	0.925	0.748	6.496 - 118.110	2.520		
150	0.551 - 1.575	0.551 - 1.417	1.299	3.150	3.149	3.268	0.472	1.102	0.827	8.071 - 118.110	2.835		
200	0.866 - 1.732	0.866 - 1.496	1.476	3.543	3.543	3.622	0.512	1.220	0.945	8.583 - 118.110	3.150		
300	0.945 - 1.890	0.945 - 1.654	1.476	4.331	3.937	4.331	0.512	1.535	0.945	8.937 - 118.110	3.268		
500	1.378 - 2.441	1.378 - 2.126	1.614	4.685	4.488	4.803	0.591	1.693	1.083	9.882 - 118.110	3.543		

Transmission of the couplings transmissible torque T can not longer be guaranteed for certain with borings $< d_{min}$. Types with borings $< d_{min}$, however, can be supplied.

Characteristics

- Metal bellows made of stainless steel, hubs made of aluminum
- Precision line shaft made of aluminum
- Optional line shaft made of CFK
- Backlash-free and torsionally rigid
- The shaft tolerance should be within the fit tolerance "g6" or "h7"
- The contact surfaces have to be free from oil and grease

The torque values shown in the technical data tables can only be safely transmitted if all instructions are followed.

Ordering example: GWZ 5106

Series Size	Total length L	Bore diameter d_1	Bore diameter d_2	Further details*
GWZ 5106 18	19.685	0.394	0.984	*

* Keyway or stainless steel

GERWAH® GWZ 5106

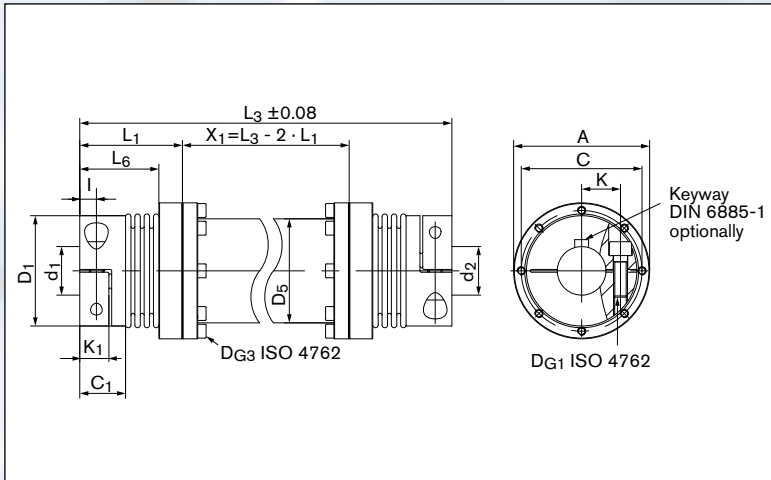

Sectional view GWZ 5106

Technical Data

- T** = Transmissible torque at given T_A
- C_m** = Torsional stiffness of extension tube per meter
- ΔKw** = Max. permissible angular misalignment
- D_{G1}** = Thread
- T_{A1}** = Tightened torque of clamping screw D_{G1}

Technical Data

	Size	T	C_m	ΔKw	D_{G1}	T_{A1}
		ft-lbs	ft-lbs/rad	degree	mm	ft-lbs
	18	16	2393	1	1 x M5	4.4
	30	27	4892	1	1 x M6	9
	60	55	8714	1	1 x M8	22
	150	133	36826	1	1 x M10	63
	200	177	55905	1	1 x M12	74
	300	266	67235	1	1 x M12	89
	500	443	149876	1	1 x M14	140

Transmissible torque T [Nm]

Size	Ø mm Ø inch																					
	8 0.315	9 0.354	10 0.394	11 0.433	12 0.472	14 0.551	15 0.591	18 0.707	20 0.787	22 0.866	Ø24 0.945	25 0.984	28 1.102	30 1.181	35 1.378	40 1.575	45 1.772	50 1.989	55 2.165	60 2.362	64 2.520	
18	10	11	13	14	15	16	16	16	16	16	16	16	---	---	---	---	---	---	---	---	---	
30	---	---	21	22	24	27	27	27	27	27	27	27	27	27	---	---	---	---	---	---	---	---
60	---	---	---	---	46	54	55	55	55	55	55	55	55	55	55	---	---	---	---	---	---	---
150	---	---	---	---	---	123	133	133	133	133	133	133	133	133	133	133	---	---	---	---	---	---
200	---	---	---	---	---	---	---	---	---	177	177	177	177	177	177	177	177	---	---	---	---	---
300	---	---	---	---	---	---	---	---	---	---	252	252	252	252	252	252	252	252	252	252	---	---
500	---	---	---	---	---	---	---	---	---	---	---	---	---	---	443	443	443	443	443	443	443	443

Backlash-free Metal Bellows Couplings · Mounting Instructions

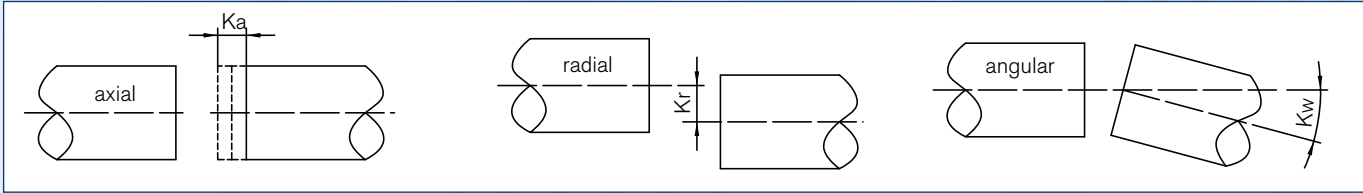

Mounting

Clean and degrease shaft ends and bores in hubs and check the tolerances. Insert both shaft ends into the hubs of the metal bellows coupling. Firmly tighten the screws after examining the axial installation dimensions. The tightening torque of the screws and the maximum approved misalignment should not be exceeded (refer to the list of technical data).

Removal

After loosening the backlash-free shaft hub connections, the drive can be pulled apart and the metal bellows coupling can be removed. Conical bushings of series AK are forced off with a hexagonal socket screw.

Alignment

If several types of misalignment occur simultaneously, none of them must reach the maximal value but must be adjusted. The sum of all actual misalignments must not exceed 100% (percentage of the maximum value). The diagram shows how to adjust. The more precise the alignment, the more reserves are available to handle additional misalignments during the operation. This will have an advantageous effect on the durability, quietness and the accuracy of transmission.

Please ask for our detailed mounting instructions.

Design example

Application:

A bellows coupling CKN 80/2.441 has to be installed. The following misalignment values result from the installation situation:

$$\Delta K_r = 0.00394 \text{ mm}$$

$$\Delta K_a = 0.00394 \text{ mm}$$

$$\Delta K_w = 0.2^\circ$$

Are the misalignment values for the CKN 80/2.441 acceptable?

Selection:

The tolerable misalignment values are: (cp. data sheet Series CKN):

$$\Delta K_r = 0.008 \text{ in}$$

$$\Delta K_a = 0.02 \text{ in}$$

$$\Delta K_w = 1.5^\circ$$

The reached radial misalignment $\Delta K_r = 0.00394 \text{ in}$ corresponds to 50% of the max. tolerable value.

The value $\Delta K_a = 0.00394 \text{ in}$ corresponds to 20% of the max. tolerable axial misalignment.

The angular misalignment with $\Delta K_w = 0.2^\circ$ corresponds to 13% of the overall view.

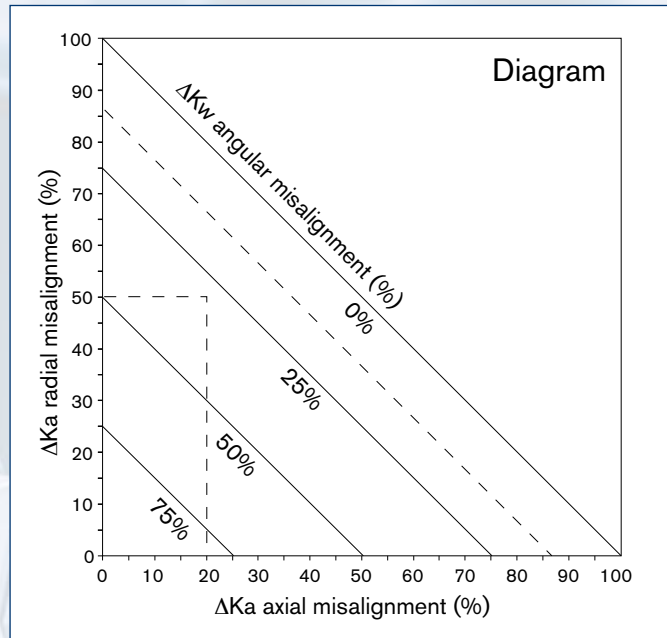

Interpretation by means of the diagram:

Enter the calculated values in the diagram on the right side (dashed line). The combination of the different misalignment values is within the tolerable area.

Interpretation by means of the empirical formula:

$$50\% + 20\% + 13\% < 100\%$$

The coupling can be installed.

$$\text{Empirical formula: } \frac{\text{(Installation situation)}}{\text{(Data sheet)}} \cdot \frac{\Delta K_r}{\Delta K_r} \cdot 100\% + \frac{\Delta K_a}{\Delta K_a} \cdot 100\% + \frac{\Delta K_w}{\Delta K_w} \cdot 100\% < 100\%$$

Backlash-free Servo-Insert Couplings · Mounting Instructions

Mounting

Clean and degrease both shaft surface and hub bores. The shaft tolerance should be within the fit tolerance “g6” or “h7”.

Slide a coupling hub onto each shaft end and tighten the screws after checking the axial dimensions. Refer to the list of technical data to get the correct tightening torque for the screws.

Firmly press the elastomeric spider into one of the two hubs. A PU compatible grease such as Vaseline may be applied to ease assembly. The edges of the spider and the jaws of the coupling hubs are both chamfered for an easier or – if applicable - blind assembly. The burlings sidewise alternate on the edges, ease the assembly and prevent from an too tight installation. Now push in the second hub. Always keep within the clearance, so that the elastomeric spider will not be tensed up axial. Therefore a longer durability and electrical isolation will be guaranteed.

IMPORTANT: For application with high dynamics

For application with high dynamics (frequent acceleration and reversion of rotating) or high impact load (applications like presses and shredders) we recommend to use the support of the Engineering-Team in doing the dimensioning and choosing the appropriated coupling.

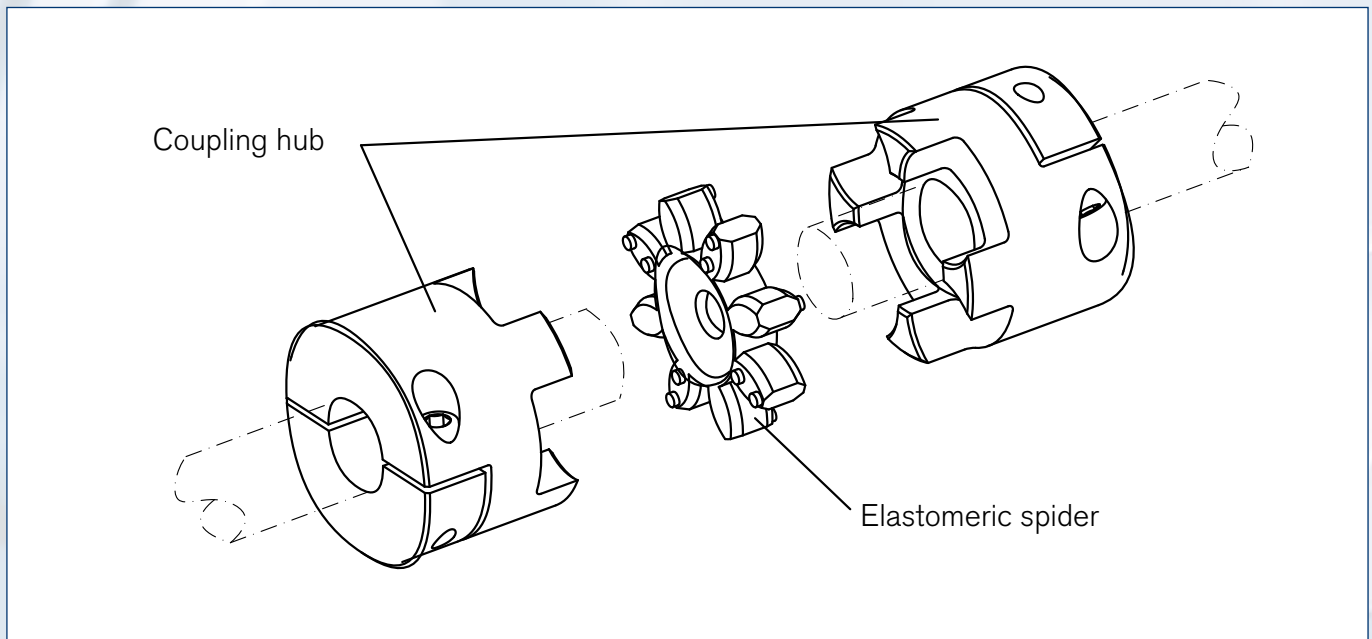
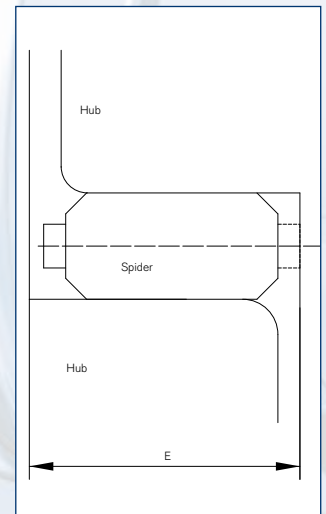
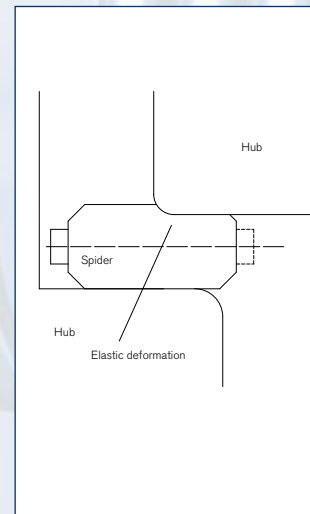
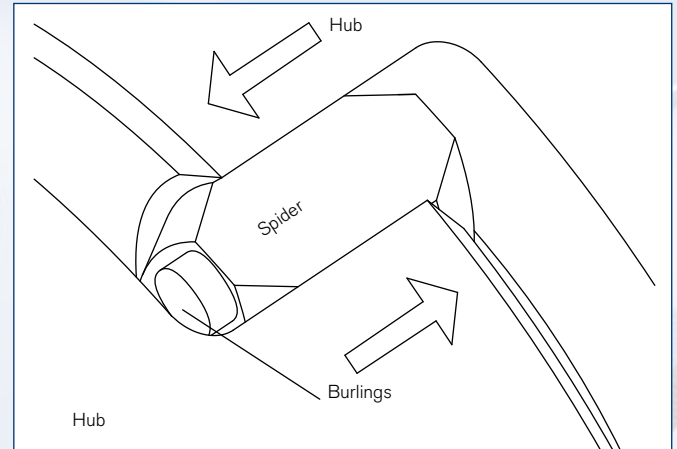

Backlash-free Servo-Insert Couplings · Mounting Instructions

Alignment

The picture above shows the three types of misalignment. The mounted coupling needs to be aligned. The more accurate the initial alignment, the better the coupling can absorb additional misalignments during operation. Durability and quietness are favourably influenced. If all three types of misalignment occur simultaneously, each type must not reach the maximum allowable value, but has to be adjusted.

The total amount of the actual misalignment types, expressed as a percentage of the maximum allowable value, must not exceed 100%. The diagram on the right side shows such an adjustment.

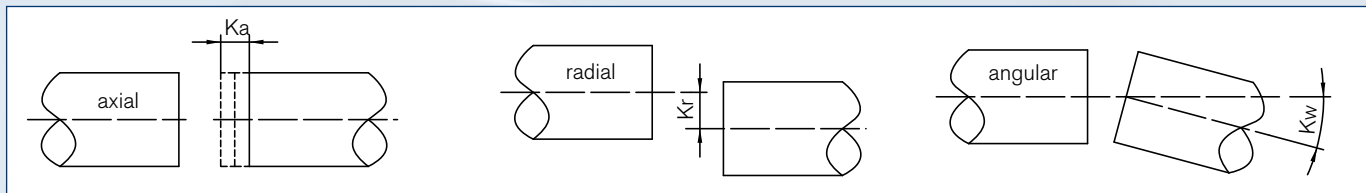
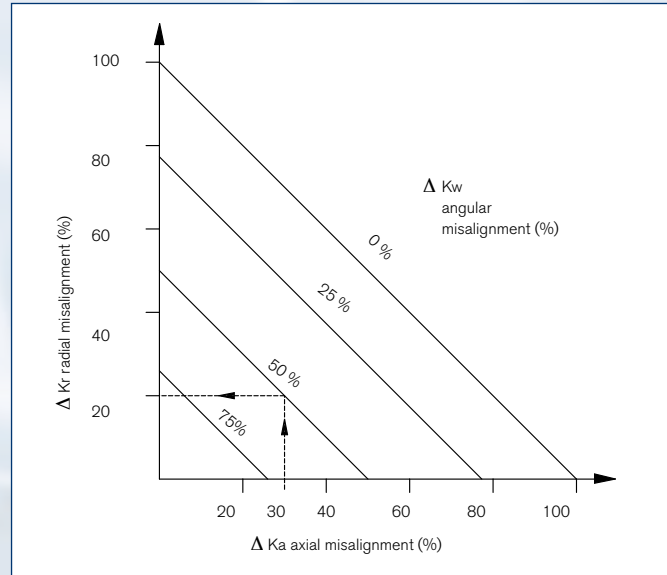

Removal

Remove the fastening screws, e.g. on the motor. Pull the drive unit, including the Servo-Insert Coupling apart. A new spider or a spider with a different shore hardness can now be installed. After loosening the backlash-free shaft-hub-connection the hubs can be disassembled.

Please ask for a detailed instruction sheet.

GERWAH Line Shafts · Mounting Instructions

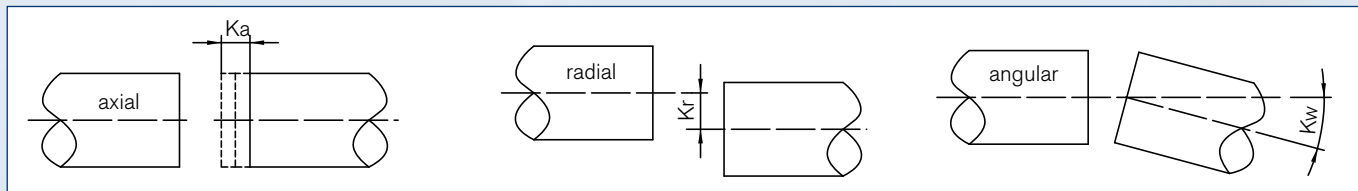

Alignment of the shafts:

The picture shows the several types of misalignment. It is necessary to adjust the shafts before assembly. The more accurate the initial alignment, the better the shaft can absorb additional misalignments during operation. Durability of the line shafts and quietness of the drive are favourably influenced.

In case all three types of misalignment occur simultaneously, each type must not reach the maximum allowable value, but have to be aligned.

Mounting:

Slide the clamping hubs on the clean and degreased shafts (or fit it when half-shell variant).

After checking the axial dimensions tighten the screws according to the technical data (Ma) for wrench torque listed in the catalogue.

The dimension on the shaft distance X (see technical drawing) should be kept.

Removal:

Remove the locking screws of the hubs. Line Shafts in split hub designs GWZ 5106 and GWZ 5106.1 lift up. For an easy removing of the GWZ 5116 intermediate pipe, shift the unfastened clamping hubs outwards (on GWZ 5104.1 to the center).

Please ask for detailed mounting instructions or find information on www.ringfeder.com!

Misalignments Servo-Insert Line Shafts

Size	Shifting		
	mm radial* ΔKr	mm axial ΔKa	Degree angular ΔKw
14	0,197 in	$\pm 0,039$ in	1,5°
19	0,197 in	$\pm 0,039$ in	1,5°
24	0,197 in	$\pm 0,039$ in	1,5°
28	0,197 in	$\pm 0,039$ in	1,5°
38	0,197 in	$\pm 0,039$ in	1,5°
42	0,197 in	$\pm 0,039$ in	1,5°
48	0,197 in	$\pm 0,039$ in	1,5°

*Radial/parallel misalignment depends on the length of the tube.

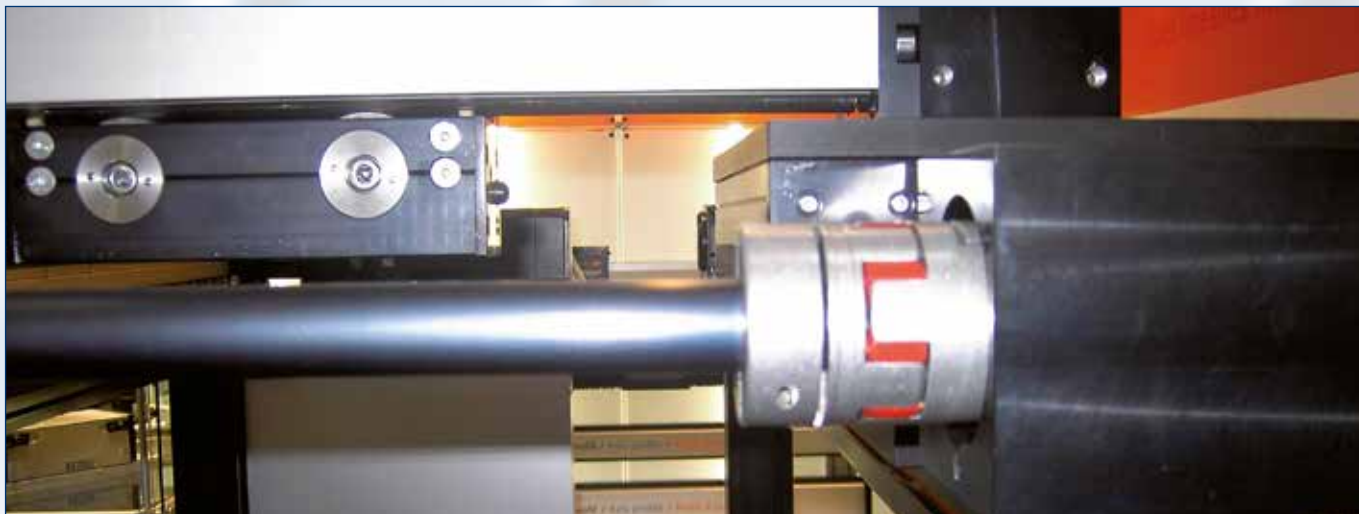

Critical bending speed

Critical bending speed for line shafts (operating speed = critical bending speed / 1,4)

GWZ 5104.1

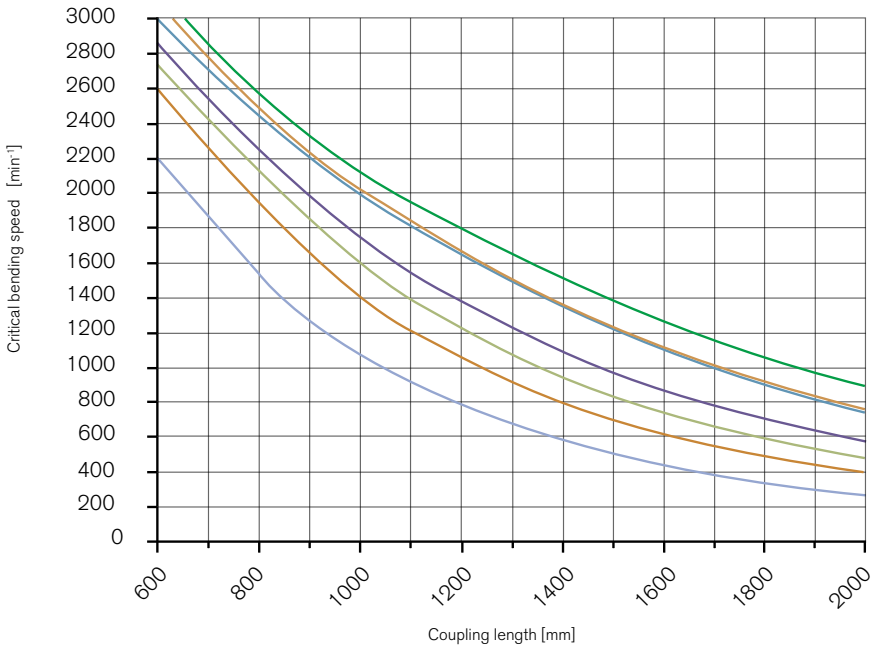

Explanation

- Size 48

- Size 42

- Size 38

- Size 28

- Size 24

- Size 19

- Size 14

GWZ 5106.1

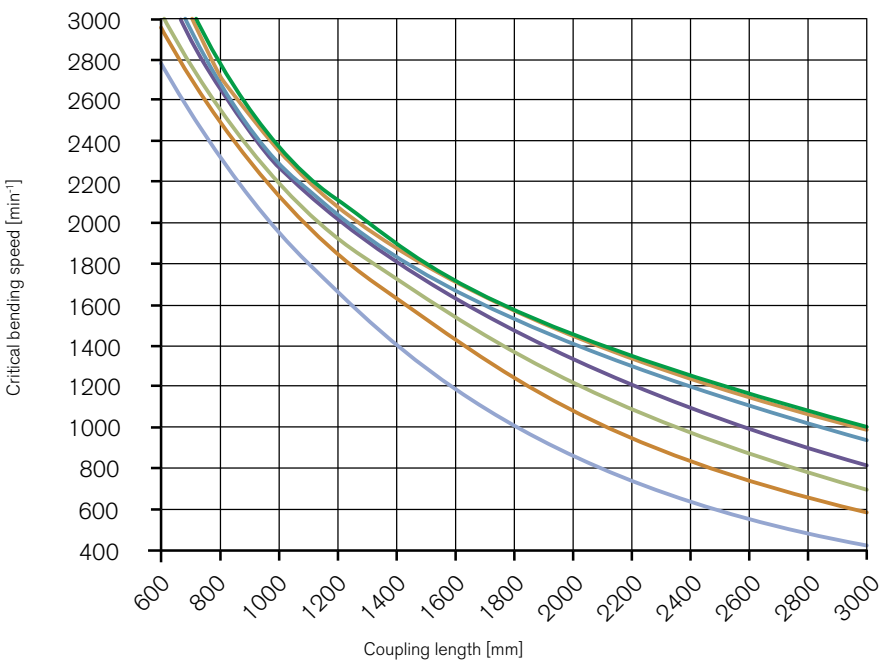

Explanation

- Size 48

- Size 42

- Size 38

- Size 28

- Size 24

- Size 19

- Size 14

Critical bending speed

Critical bending speed for line shafts (operating speed = critical bending speed / 1,4)

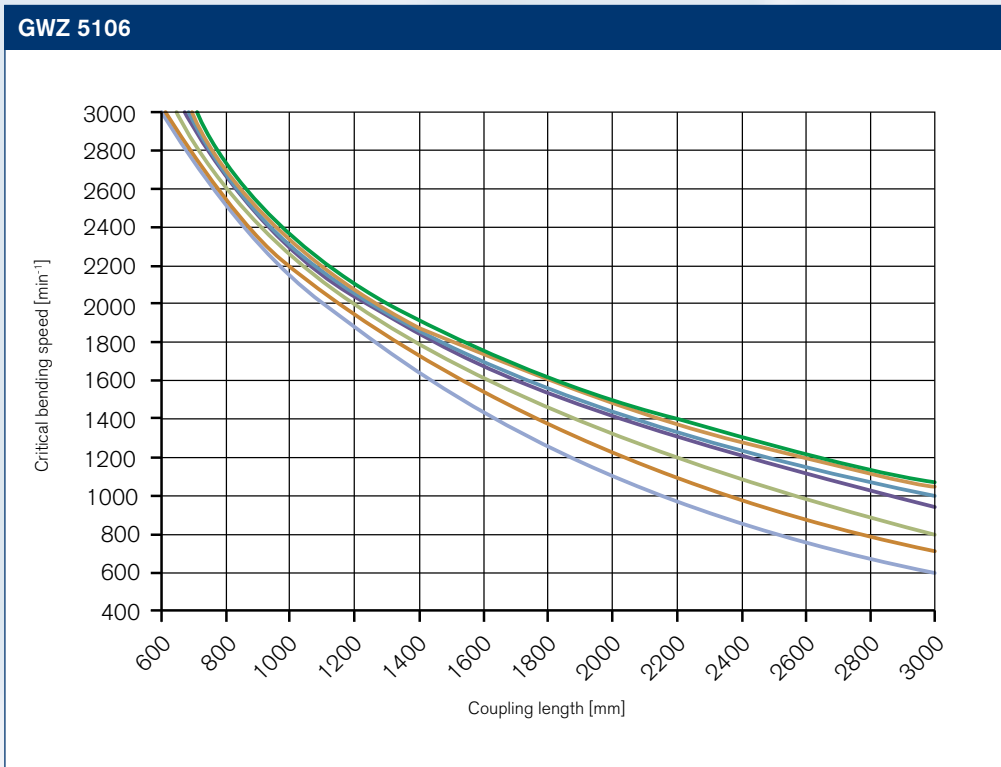

Explanation

- Size 48

- Size 42

- Size 38

- Size 28

- Size 24

- Size 19

- Size 14

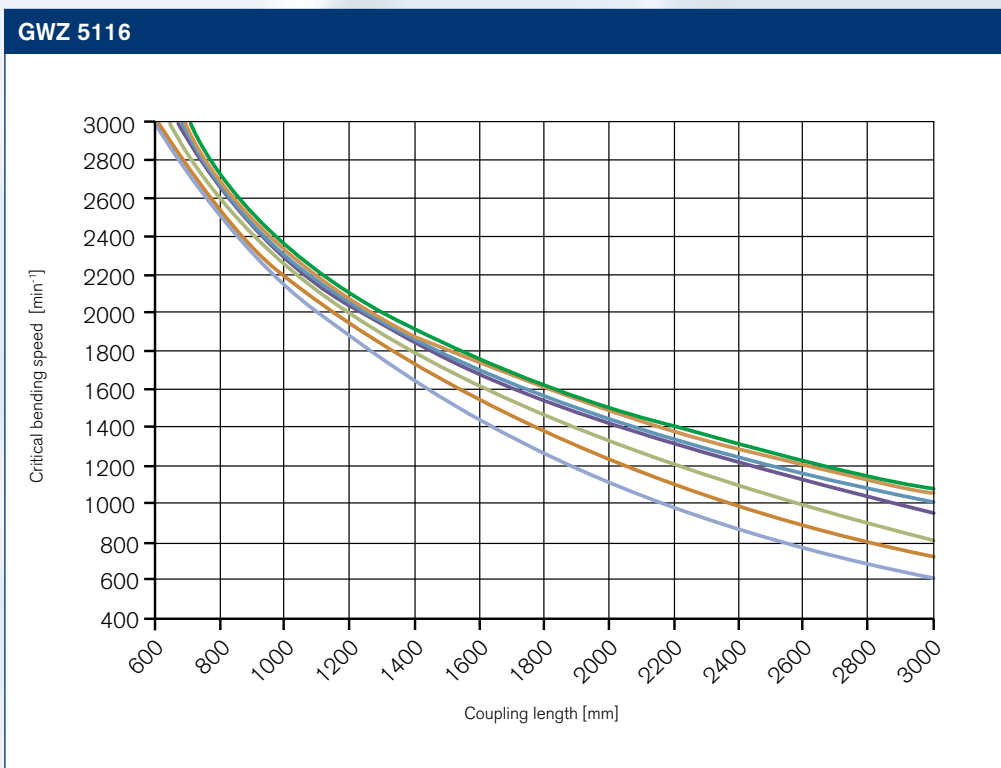

Explanation

- Size 48

- Size 42

- Size 38

- Size 28

- Size 24

- Size 19

- Size 14

Fax Inquiry Couplings

On this page please explain the planned application of a GERWAH® coupling and we will propose our solution. Please send this page to:

RINGFEDER POWER TRANSMISSION USA CORPORATION

FAX: +1 201 664 6053

1. Application

Planned use of the coupling (machine, machine group or plant):

2. Type of attachment (please tick/check)

- | | | | |
|---------------------------------------|-------------------------------------|--|--|
| <input type="checkbox"/> Clamping hub | <input type="checkbox"/> Cone hub | <input type="checkbox"/> Expanding hub | <input type="checkbox"/> Hub with set screw |
| <input type="checkbox"/> Flange mount | <input type="checkbox"/> Outer cone | <input type="checkbox"/> Fanuc | <input type="checkbox"/> Acc. customer request |

3. Dimensions

- | | | |
|--|---|-----------------------------|
| <input type="text"/> Length (Inches) | <input type="text"/> Bore D ₁ (Inches) | <input type="text"/> Keyway |
| <input type="text"/> Outer diameter (Inches) | <input type="text"/> Bore D ₂ (Inches) | <input type="text"/> Keyway |

4. Shaft misalignment

- | | | |
|-------------------------------------|--------------------------------------|---------------------------------------|
| <input type="text"/> Axial (Inches) | <input type="text"/> Radial (Inches) | <input type="text"/> Angular (Degree) |
|-------------------------------------|--------------------------------------|---------------------------------------|

5. Drive

- | | | | |
|-------------|------------------------------|-----------------------------|--|
| Drive power | P = <input type="text"/> HP | Nominal torque of the drive | Mt _{nom} = <input type="text"/> lb-in |
| Input speed | n = <input type="text"/> rpm | Peak torque of the drive | Mt _{max} = <input type="text"/> lb-in |

6. Mass moment of inertia

- | | | | |
|-------------------|--|--------------------|--|
| On the drive side | J _A = <input type="text"/> lb-in ² | On the driven side | J _L = <input type="text"/> lb-in ² |
|-------------------|--|--------------------|--|

7. Environmental influences

- | | | | | |
|---|--------------------------------|--|---------------------------------|--------------------------------|
| Temperature in the area of the coupling | Temp = <input type="text"/> °F | Special materials (e.g. stainless steel) | <input type="text"/> | |
| Are there any impacts on the load side? | <input type="checkbox"/> No | <input type="checkbox"/> Slight | <input type="checkbox"/> Medium | <input type="checkbox"/> Heavy |
| Other, special influences | <input type="text"/> | | | |

8. Estimated demand

9. Target price

- | | | | | |
|---------------------------------|----------------------------------|---------------------------------|---|------------------------------|
| <input type="checkbox"/> Series | <input type="checkbox"/> Project | <input type="checkbox"/> Repair | <input type="text"/> Number of items/p.a. | <input type="text"/> \$/Each |
|---------------------------------|----------------------------------|---------------------------------|---|------------------------------|

Please send your offer to:

- | | | | |
|---------|----------------------|-----------|----------------------|
| Company | <input type="text"/> | Attention | <input type="text"/> |
| Address | <input type="text"/> | | |
| Phone | <input type="text"/> | Fax | <input type="text"/> |
| E-mail | <input type="text"/> | | |

Fax Inquiry Line Shafts

On this page please explain the planned application of a GERWAH® line shaft and we will propose our solution. Please send this page to:

RINGFEDER POWER TRANSMISSION USA CORPORATION

FAX: +1 201 664 6053

1. Application

Planned use of the coupling (machine, machine group or plant):

2. Type of attachment (please tick/check)

- Clamping hub Cone hub Flange mount Hub with half-shell
 Outer cone Acc. customer request

3. Dimensions

- Total length (Inches) Bore D₁ (Inches) Keyway
 Dimension shafts distance (Inches) Bore D₂ (Inches) Keyway

4. Shaft misalignment

- Axial (Inches) Radial (Inches) Angular (Degree)

5. Drive

- Drive power P = HP Nominal torque of the drive Mt_{nom} = lb-in
Input speed n = rpm Peak torque of the drive Mt_{max} = lb-in

6. Mass moment of inertia

- On the drive side J_A = lb-in² On the driven side J_L = lb-in²

7. Environmental influences

- Temperature in the area of the coupling Temp = °F Special materials (e.g. stainless steel)
Are there any impacts on the load side? No Slight Medium Heavy
Other, special influences

8. Estimated demand

9. Target price

- Series Project Repair Number of items/p.a. \$/Each

Please send your offer to:

- Company Attention
Address
Phone Fax
E-mail

Calculation program for Locking Assemblies and Locking Elements

In order to meet the complex requirements on the correct design and selection of RINGFEDER products under practise-relevant demands, RINGFEDER POWER TRANSMISSION has developed a calculation program.

This calculation program offers the engineer a valuable aid in his or her daily work and simplifies the calculation of a wide range of tasks.

Once a product and the desired product size have been selected the program carries out the calculation, taking into account additional user input e.g. **transmissible torque and axial forces, resulting hub and shaft pressure, the outer diameter of the hub, the inner diameter of the hollow shaft** and for special tasks even the **forces and loads under bending moment loads**.

Interested? Visit our Website at www.ringfeder.com!

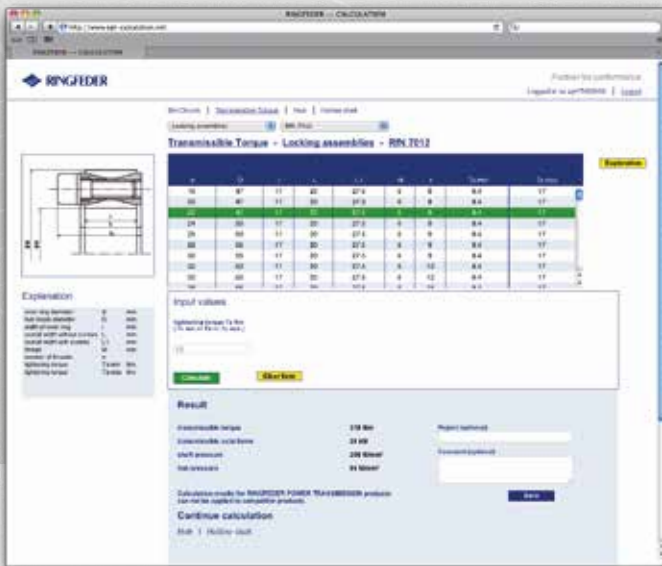

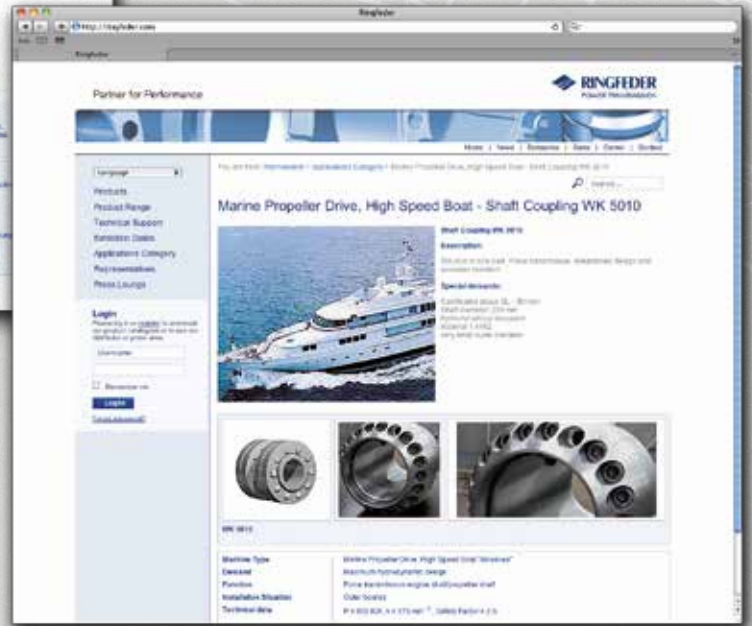

Our Website

Easily accessible information.

RINGFEDER POWER TRANSMISSION – one of the top addresses for drive and damping technology in mechanical engineering. You can find first-hand service details and information on our website. It contains both details on our entire range

of products and numerous documents such as product catalogues, data sheets and assembly instruction for you to download.

Visit www.ringfeder.com to get right up to date.



Download area Product Range and catalogues



Available Instructions for Installation, Removal and Maintaining



Locking Devices



Locking Assemblies



Locking Assemblies for bending moments



Locking Assemblies - Stainless steel



Locking Elements

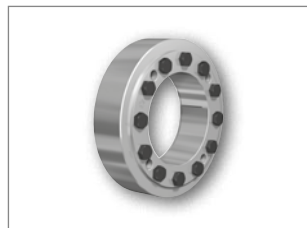

Shrink Discs



Flange Couplings

Damping Technology



Friction Springs



DEFORM plus®



DEFORM plus® R



Couplings



Torsionally Flexible Couplings



Torsionally Flexible Couplings



Torsionally Flexible Couplings



Torsionally Rigid Gear Couplings



Torsionally Rigid Barrel Coupling



Couplings with variable Stiffness



Couplings



Flexible Couplings Henflex



Hydrodynamic Couplings Henfluid

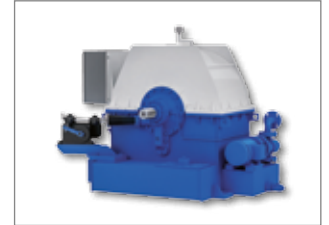

Hydrodynamic Couplings with variable speed

Bearing Housings



Bearing Housings

Remark:

HENFEL products are only available in South America and selected markets.



Couplings



Metal Bellows Couplings



Servo-Insert Couplings



Safety Couplings



Line Shafts

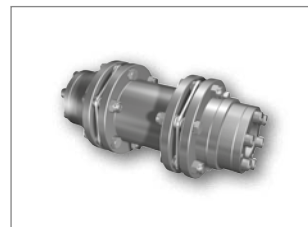

Torsionally Rigid Disc Couplings



RINGFEDER POWER TRANSMISSION GMBH

Werner-Heisenberg-Straße 18, D-64823 Groß-Umstadt, Germany · Phone: +49 (0) 6078 9385-0 · Fax: +49 (0) 6078 9385-100
 E-mail: sales.international@ringfeder.com

RINGFEDER POWER TRANSMISSION TSCHAN GMBH

Zweibrücker Straße 104, D-66538 Neunkirchen, Germany · Phone: +49 (0) 6821 866-0 · Fax: +49 (0) 6821 866-4111
 E-mail: sales.tschan@ringfeder.com

RINGFEDER POWER TRANSMISSION USA CORPORATION

165 Carver Avenue, Westwood, NJ 07675, USA · Toll Free: +1 888 746-4333 · Phone: +1 201 666 3320 · Fax: +1 201 664 6053
 E-mail: sales.usa@ringfeder.com

HENFEL INDÚSTRIA METALÚRGICA LTDA.

Av. Major Hilário Tavares Pinheiro, 3447 · Cer 14871 300 · Jaboticabal - SP - Brazil · Phone: +55 16 3209-3422
 Fax: +55 16 3202-3563 · E-mail: vendas@henfel.com.br

RINGFEDER POWER TRANSMISSION INDIA PRIVATE LIMITED

Plot No. 4, Door No. 220, Mount - Poonamallee Road, Kattupakkam, Chennai – 600 056, India
 Phone: +91 (0) 44-2679 1411 · Fax: +91 (0) 44-2679 1422 · E-mail: sales.india@ringfeder.com

KUNSHAN RINGFEDER POWER TRANSMISSION COMPANY LIMITED

No. 10 Dexin Road, Zhangpu Town 215321, Kunshan, China
 Phone: +86 (0) 512-5745-3960 · Fax: +86 (0) 512-5745-3961 · E-mail: sales.china@ringfeder.com